

**GOVERNMENT POLYTECHNIC  
KENDRAPARA**

**DEPARTEMENT OF CIVIL  
ENGINEERING**



**LECTURE NOTE**

**SUBJECT:-WATER SUPPLY & WASTE WATER  
ENGINEERING**

**PREPARED BY- JYOTIRMAYEE SAMAL & BIJAYA KUMAR ROUT  
SEMESTER:- 5TH  
YEAR:- 3RD**

## Th4. WATER SUPPLY AND WASTE WATER ENGINEERING

Name of the Course: Diploma in Civil Engineering			
Course code:		Semester	5 <sup>th</sup>
Total Period:	75	Examination	3 hrs
Theory periods:	5P/week	Class Test:	20
Maximum marks:	100	End Semester Examination:	80

### A. RATIONALE

The course aims to expose the students to the current state of water supply and sewage disposal system. Through the course the principles, purposes and the methods are covered at different stages of the activity, thus laying foundation in students to think of meeting futuristic challenges.

### B. COURSE OBJECTIVES

On completion of the course, students will be able to

1. Compute water demand in terms of quantity and quality
2. Describe the water sources, conveyance and distribution system
3. Realize the necessity of treatment and comprehend the principle and purpose of different water treatment processes
4. Comprehend the terminology relating to sanitary engineering and compute quantity & quality of sewage
5. Describe the sewerage system and its components stating the purposes thereof
6. Comprehend the necessity and method of sewage treatment and disposal

### C. TOPIC WISE DISTRIBUTION OF PERIODS

Chapter	Name of topics	Hours
<b>SECTION A: WATER SUPPLY</b>		
1	Introduction to Water Supply, Quantity and Quality of water	10
2	Sources and Conveyance of water	8
3	Treatment of water	12
4	Distribution system and Appurtenance in distribution system	8
5	W/s plumbing in building	2
<b>SECTION B: WASTE WATER ENGINEERING</b>		
6	Introduction	5
7	Quantity and Quality of sewage	7
8	Sewerage system	5
9	Sewer appurtenances and Sewage Disposal	7
10	Sewage treatment	8
11	Sanitary plumbing for building	3

### D. COURSE CONTENTS:

#### SECTION A: WATER SUPPLY

#### 1 Introduction to Water Supply, Quantity and Quality of water

Necessity of treated water supply

Per capita demand, variation in demand and factors affecting demand

Methods of forecasting population, Numerical problems using different methods  
Impurities in water – organic and inorganic, Harmful effects of impurities  
Analysis of water –physical, chemical and bacteriological  
Water quality standards for different uses

## 2 Sources and Conveyance of water

Surface sources – Lake, stream, river and impounded reservoir  
Underground sources – aquifer type & occurrence – Infiltration gallery, infiltration well, springs, well  
Yield from well- methods of determination, Numerical problems using yield formulae (deduction excluded)  
Intakes – types, description of river intake, reservoir intake, canal intake  
Pumps for conveyance & distribution – types, selection, installation.  
Pipe materials – necessity, suitability, merits & demerits of each type  
Pipe joints – necessity, types of joints, suitability, methods of jointing Laying of pipes – method

## 3 Treatment of water

*Note:*

1. *Design of treatment units excluded.*
2. *Students may be asked to prepare detailed sketches of units, preferably from working drawing, as home assignment*
3. *Field visit to treatment plant, under practical should be arranged after covering this unit.*

Flow diagram of conventional water treatment system

Treatment process / units :

Aeration ; Necessity

Plain Sedimentation : Necessity, working principles, Sedimentation tanks – types, essential features, operation & maintenance

Sedimentation with coagulation: Necessity, principles of coagulation, types of coagulants, Flash Mixer, Flocculator, Clarifier (Definition and concept only)

Filtration : Necessity, principles, types of filters

Slow Sand Filter, Rapid Sand Filter and Pressure Filter – essential features

Disinfection : Necessity, methods of disinfection

Chlorination – free and combined chlorine demand, available chlorine, residual chlorine, pre-chlorination, break point chlorination, super-chlorination

Softening of water – Necessity, Methods of softening – Lime soda process and Ion exchange method (Concept Only)

## 4 Distribution system And Appurtenance in distribution system:

General requirements, types of distribution system-gravity, direct and combined

Methods of supply – intermittent and continuous

Distribution system layout – types, comparison, suitability

Valves-types, features, uses, purpose-sluice valves, check valves, air valves, scour valves, Fire hydrants, Water meters

## 5 W/s plumbing in building :

Method of connection from water mains to building supply

General layout of plumbing arrangement for water supply in single storied and multi-storied building as per I.S. code.

## SECTION B: WASTE WATER ENGINEERING

### 6 Introduction

Aims and objectives of sanitary engineering  
Definition of terms related to sanitary engineering  
Systems of collection of wastes– Conservancy and Water Carriage System –  
features, comparison, suitability

### 7 Quantity and Quality of sewage

Quantity of sanitary sewage – domestic & industrial sewage, variation in sewageflow, numerical problem on computation quantity of sanitary sewage.  
Computation of size of sewer, application of Chazy's formula, Limiting velocities of flow : self-cleaning and scouring  
General importance, strength of sewage, Characteristics of sewage-physical,chemical & biological  
Concept of sewage-sampling, tests for – solids, pH, dissolved oxygen, BOD,COD

### 8 Sewerage system

Types of system-separate, combined, partially separate , features, comparison between the types, suitability  
Shapes of sewer – rectangular, circular, avoid-features, suitability  
Laying of sewer-setting out sewer alignment

### 9 Sewer appurtenances and Sewage Disposal:

Manholes and Lamp holes – types, features, location, function  
Inlets, Grease & oil trap – features, location, function  
Storm regulator, inverted siphon – features, location, function  
Disposal on land – sewage farming, sewage application and dosing,sewage sickness-causes and remedies  
Disposal by dilution – standards for disposal in different types of water bodies, self purification of stream

### 10 Sewage treatment :

**(Note: 1.Design of treatment units excluded.**

**2. Students may be asked to prepare detailed sketches of units, preferably from working drawing, as home assignment.**

**3.Field visit to treatment plant, under practical should be arranged after covering this unit.)**

Principles of treatment, flow diagram of conventional treatment  
Primary treatment – necessity, principles, essential features, functions  
Secondary treatment – necessity, principles, essential features, functions

### 11 Sanitary plumbing for building :

Requirements of building drainage, layout of lavatory blocks in residential buildings, layout of building drainage  
Plumbing arrangement of single storied & multi storied building as per I.S. code practice  
Sanitary fixtures – features, function, and maintenance and fixing of the fixtures – water closets, flushing cisterns, urinals, inspection chambers, traps, anti-syphonage pipe

## E. SYLLABUS COVERGE UPTO INTERNAL ASSESSMENT

Chapters 1, 2, 3, 4 from Section A & Chapters 6,7,8 from Section B

## F. RECOMMENDED BOOKS

Sl. No	Name of Authors	Titles of Book	Name of Publisher
1	G.S.Birdie	Text book on water supply and sanitary engineering	Dhanpat Rai Publications
2	S.K.Garg	Water Supply Engineering	Khanna Publishers
3	S.K.Garg	Waste Water Disposal Engg.	Khanna Publishers
4	By Ministry of Urban Development, Govt. of India.	CPHEEO manual Water supply	
5	By Ministry of Urban Development, Govt. of India.	CPHEC Mannual- Sewage & Sewage Treatment - by Ministry of Urban Development, Govt. of India.	

## CHAPTER 1

# INTRODUCTION TO WATER SUPPLY, QUANTITY AND QUALITY OF WATER

### Introduction to Water Supply

- Water is one of the essential requirements for life.
- All living things need water for their survival.
- Water is used for a variety of purposes, including drinking, food preparation, irrigation and manufacturing.
- Although water covers more than 70% of the Earth's surface, less than 1% of that resource is available as fresh water – and this is not evenly distributed throughout the world.
- Apart from the scarcity of water, there are many other challenges in providing a safe, adequate and reliable water supply in many parts of the world.
- **Water supply system**, infrastructure for the collection, transmission, treatment, storage, and distribution of water for homes, commercial establishments, industry, and irrigation, as well as for such public needs as firefighting and street flushing.
- Of all municipal services, provision of potable water is perhaps the most vital.
- People depend on water for drinking, cooking, washing, carrying away wastes, and other domestic needs.
- In all cases, the water must fulfill both quality and quantity requirements.

### **Necessity of water supply scheme**

- Collection of water
- Conveyance of water
- Treatment of water
- Distribution of water

### **Uses of water**

Water is stored in various parts of the world but not evenly distributed all over the earth. It is said to be a universal solvent. Various sources of water are – sea, lake, rain, well, stream, borehole and pond. It is used for washing, drinking, generating electricity etc. Below are the **different uses of water** in various fields:

- Domestic uses of water
- Water use for agriculture
- Industrial uses of water

Domestic uses of water:

15 % of water is consumed for domestic purpose. Water is used for drinking, bathing, cooking food and washing dishes, clothes, fruits, vegetables and brushing teeth.

Water use for agriculture:

Agriculture is the largest consumer of water. About 70% of water is used for irrigation. Water is necessary for gardening, farming and fisheries. Plants require water to grow. During the process of photosynthesis they consume water. To yield

crops, fruits, flowers, vegetables they need sufficient water, manure, sunlight and oxygen.

Industrial uses of water:

It is either used in creating or to cool the equipment used for creating the product. Industrial water is used for washing, cooling, processing, transporting, diluting or fabricating of a product. Maximum amount of water is used in the production of chemical, paper and food.

Other uses are – it is used in transportation, manufacturing, hydroelectric power, removal of body wastes, tourism and recreation.

## **Water Treatment**

- the most common steps in water treatment used by community water systems include:
- Coagulation and Flocculation

Coagulation and flocculation are often the first steps in water treatment. Chemicals with a positive charge are added to the water. The positive charge of these chemicals neutralizes the negative charge of dirt and other dissolved particles in the water. When this occurs, the particles bind with the chemicals and form larger particles, called floc.

- Sedimentation

During sedimentation, floc settles to the bottom of the water supply, due to its weight. This settling process is called sedimentation.

- Filtration

Once the floc has settled to the bottom of the water supply, the clear water on top will pass through filters of varying compositions (sand, gravel, and charcoal) and pore sizes, in order to remove dissolved particles, such as dust, parasites, bacteria, viruses, and chemicals.

- Disinfection

After the water has been filtered, a disinfectant (for example, chlorine, chloramine) may be added in order to kill any remaining parasites, bacteria, and viruses, and to protect the water from germs when it is piped to homes and businesses.

### **Sources of water supply Scheme**

There are two types

Surface water and groundwater

- Surface water and groundwater are both important sources for community water supply needs.
- Groundwater is a common source for single homes and small towns, and rivers and lakes are the usual sources for large cities.
- Although approximately 98 percent of liquid fresh water exists as groundwater, much of it occurs very deep.
- This makes pumping very expensive, preventing the full development and use of all groundwater resources.

### **Surface water**

- The total land area that contributes surface runoff to a river or lake is called a watershed, drainage basin, or catchment area.
- The volume of water available for municipal supply depends mostly on the amount of rainfall.
- It also depends on the size of the watershed, the slope of the ground, the type of soil and vegetation, and the type of land use.
- The flow rate or discharge of a river varies with time.
- Higher flow rates typically occur in the spring, and lower flow rates occur in the winter, though this is often not the case in areas with monsoon systems.
- When the average discharge of a river is not enough for a dependable supply of water, a conservation reservoir may be built.
- The flow of water is blocked by a dam, allowing an artificial lake to be formed.
- Conservation reservoirs store water from wet weather periods for use during times of drought and low streamflow.

## **Groundwater**

- The value of an aquifer as a source of groundwater is a function of the porosity of the geologic stratum, or layer, of which it is formed.
- Water is withdrawn from an aquifer by pumping it out of a well or infiltration gallery.

- An infiltration gallery typically includes several horizontal perforated pipes radiating outward from the bottom of a large-diameter vertical shaft.
- Wells are constructed in several ways, depending on the depth and nature of the aquifer.
- Wells used for public water supplies, usually more than 30 metres (100 feet) deep and from 10 to 30 cm (4 to 12 inches) in diameter, must penetrate large aquifers that can provide dependable yields of good-quality water.

## **Water Requirements**

Municipal water supply systems include facilities for storage, transmission, treatment, and distribution. The design of these facilities depends on the quality of the water, on the particular needs of the user or consumer, and on the quantities of water that must be processed.

## **Drinking-water quality**

- Water has such a strong tendency to dissolve other substances that it is rarely found in nature in a pure condition.
- When it falls as rain, small amounts of gases such as oxygen and carbon dioxide become dissolved in it; raindrops also carry tiny dust particles and other substances.

- As it flows over the ground, water picks up fine soil particles, microbes, organic material, and soluble minerals.
- In lakes, and swamps, water may gain colour, taste, and odour from decaying vegetation and other natural organic matter.
- Groundwater usually acquires more dissolved minerals than does surface runoff because of its longer direct contact with soil and rock. It may also absorb gases such as hydrogen sulfide and methane.
- In populated areas the quality of surface water as well as groundwater is directly influenced by land use and by human activities.
- For example, stormwater runoff contaminated with agricultural or lawn pesticides and fertilizers, as well as with road deicing chemicals or motor oil, can flow into streams and lakes. In addition, effluent from malfunctioning septic tanks and subsurface leaching fields can seep into groundwater.

## **Health concerns**

- Five general types of impurities are of public health concern.
- These are organic chemicals, inorganic chemicals, turbidity, microorganisms, and radioactive substances.
- Organic contaminants include various pesticides, industrial solvents, and trihalomethanes such as chloroform.

- Inorganic contaminants of major concern include arsenic, nitrate, fluoride, and toxic metals such as lead and mercury.
- All these substances can harm human health when present above certain concentrations in drinking water.
- A low concentration of fluoride, however, has been proved to promote dental health.
- Some communities add fluoride to their water for this purpose.

### **Aesthetic concerns**

- Colour, taste, and odour are physical characteristics of drinking water that are important for aesthetic reasons rather than for health reasons.
- Colour in water may be caused by decaying leaves or by algae, giving it a brownish yellow .
- Taste and odour may be caused by naturally occurring dissolved organics or gases.
- Some well-water supplies, for example, have a rotten-egg odour that is caused by hydrogen sulfide gas.
- Chemical impurities associated with the aesthetic quality of drinking water include iron, manganese, copper, zinc, and chloride.
- Dissolved metals impart a bitter taste to water and may stain laundry and plumbing fixtures.

- Excessive chlorides give the water an objectionable salty taste.

## **Hardness**

- Another parameter of water quality is hardness. This is a term used to describe the effect of dissolved minerals (mostly calcium and magnesium).
- Minerals cause deposits of scale in hot water pipes, and they also interfere with the lathering action of soap.
- Hard water does not harm human health, but the economic problems it causes make it objectionable to most people.

## **Standards**

- Water quality standards set limits on the concentrations of impurities allowed in water.
- Standards also affect the selection of raw water sources and the choice of treatment processes.
- Modern testing methods now allow the detection of contaminants in extremely low concentrations—as low as one part contaminant per one billion parts water or even, in some cases, per one trillion parts water.
- Water quality standards are continually evolving, usually becoming more stringent. As a result, the number of regulated contaminants increases over time, and their allowable concentrations in water are lowered.

## **Municipal water consumption**

- Water consumption in a community is characterized by several types of demand, including domestic, public, commercial, and industrial uses.
- Domestic demand includes water for drinking, cooking, washing, laundering, and other household functions.
- Public demand includes water for fire protection, street cleaning, and use in schools and other public buildings.
- Commercial and industrial demands include water for stores, offices, hotels, laundries, restaurants, and most manufacturing plants.
- There is usually a wide variation in total water demand among different communities.
- This variation depends on population, geographic location, climate, the extent of local commercial and industrial activity, and the cost of water.

## **Quantity of water**

- While designing the water supply scheme for a town or city, it is necessary to determine the total quantity of water required for various purposes by the city.
- The first duty of the engineer is to determine the water demand of the town and then to find out the suitable water sources from where demand can be met.

## **Types of Demand**

Following are the various types of water demand of a city or town:

1. Domestic Water Demand
2. Commercial
3. Industrial Demand
4. Fire-Demand
5. Demand for Public Use
6. Compensate Losses Demand.

***Domestic Water Demand:***

- It includes the quantity of water required in the houses for drinking, bathing, cooking, washing etc.
- The quantity of water required for domestic use mainly depends on the habits, social status, climatic conditions and customs of the people.
- In India on an average, the domestic consumption of water under normal condition is about 135 litres/day/capita as per IS: 1172-1171.
- In developed countries this figure may be as high as 350 litres/day/ capita.
- The increase in water consumption in developed countries is mainly due to use of air coolers, air conditioners, maintenance of lawns, automatic household appliances such as home laundries, disc washers etc.
- The total consumption in this demand, generally amounts to 55 to 60% of the total water consumption the breakup of 135 litres/day/person may be taken as shown in Table

<i>Use</i>	<i>Consumption in litres /day/ person</i>
(a) Drinking	5
(b) Cooking	5
(c) Bathing	55
(d) Washing of clothes	20
(e) Washing of utensils	10
(f) Washing and cleaning of houses and residences	10
(g) Flushing of Latrines etc.	30
Total	135

***Commercial:***

Commercial building and commercial centres include office building, warehouse, stores, hotels, shopping centres, health centres, schools, temples, cinema houses, railway and bus stations etc. The water requirements of commercial and public places may be up to 45 litres/day/capita. Table gives the water demand for buildings other than residences as per IS: 1172-1963.

Water supply Requirements for Public Building other than Residence (As per IS; 1172-1963 Indian Standard Code of Basic Requirements for Water Supply, Drainage and Sanitation).

<i>S.No.</i>	<i>Type of Building</i>	<i>Construction per capita per day Litres</i>
1.	(a) Factories where bathrooms are <u>required</u> to be provided	45
	(b) Factories where no bathrooms are required to be provided	30
2.	Hospitals (including laundry) per bed	
	(a) No. of beds not exceeding 100	340
	(b) No. of beds exceeding 100	450
3.	Nurses homes and medical quarters	135
4.	Hostels	135
5.	Offices	45
6.	Restaurants (per seat)	70
7.	Hotel (per bed)	180
8.	Cinema concert hall and theatres (per seat)	15
	Schools	
	(a) Day Schools	45
	(b) Boarding schools	135
9.	Garden, sports grounds	3.5 per sq. m.
10.	Animals/vehicles	45

### Industrial Demand

The water required in the industries mainly depends on the type and size of industries which are existing in the city. The quantity of water required by industries is also expressed in terms of per capita demand. The water required by factories, paper mills, clothe mills, cotton mills, breweries, sugar refineries etc. comes under industrial use. The quantity of water demand for industrial purposes is around 20 to 25% of the total demand of the city.

### ***Fire Demand:***

Fires generally break in thickly populated localities and the industrial area, and cause serious damages of properties and sometimes lives of the people are lost.

Fire may take place due to faulty electric wires by short circuiting, fire catching materials, explosions, bad intention of criminal people or any other unforeseen mishappenings. If fires are not properly controlled and extinguished in minimum possible time, they lead to serious damages and may burn the cities.

All the big cities have full fire-fighting squads. As during fire-breakdowns large quantity of water is required for throwing it over the fire to extinguish it, therefore provision is made in the water works to supply sufficient quantity of water or keep as reserve in the water mains for this purpose, in the cities fire-hydrants are provided on the water mains at 100 to 150 m apart. Fire brigade men immediately connect these fire-hydrants with their engines and start throwing water at very high rate on the fire.

The minimum water pressure available at fire hydrants should be of the order of 1.0 to 1.5 kg/cm<sup>2</sup> and should be maintained even after 4 to 5 hours of constant use of fire hydrant.

### **Kuichling's Formula:**

$$Q = 3182\sqrt{P}$$

### ***Demand for Public Use:***

Quantity of water required for public utility purposes such as for washing and sprinkling of roads cleaning of sewers, watering of public parks, gardens, public fountains etc., comes under public demand. To meet the water demand for public use, provision of 5% of the total consumption is made while designing the water works for a city.

### ***Compensate Losses Demand:***

All the water which goes in the distribution pipe does not reach the consumers. Some portion of this is wasted in the pipe lines due to defective pipe-joints, cracked and broken pipes, faulty valves and fittings. Sometimes consumers keep open their taps or public taps even when they are not using the water and allow continuous wastage of water.

In some way, some quantity of water is lost due to unauthorised and illegal connections. While estimating the total requirement of water of a town, allowance for these losses and wastages should also be done. Generally allowance of 15% of the total quantity of water is made to compensate for losses, thefts and wastage of water.

### **Per Capita Demand:**

In community, water is used for various purposes as described above. For the purpose of estimation of total requirements of water, the demand is calculated on an average basis, which is expressed as so many litres/capita/day.

If  $Q$  is the total quantity of water required by a town per year in litres, and the population of the town is  $P$ . the per capita demand will be.

The per capita demand of the town depends on various factors and will be according to the living standard of the public and the number and type of the commercial places in the town etc.

**For an average Indian town, the requirement of water in various uses is as under:**

(i) Domestic use	135 litres/capita/day
(ii) Industrial	40 litres/capita/day
(iii) Public use	25 litres/capita/day
(iv) Business or Trade	15 litres/capita/day
(v) Losses, wastage and thefts	55 litres/capita/day
<b>Total</b>	<b><u>270 litres/capita/day</u></b>

## **FACTORS AFFECTING RATE OF DEMAND OF WATER**

### **Climatic Conditions:**

The requirement of water is more at places having hot and dry climate than at places having cold and humid climate. This is so because at places having hot and dry climate more water is required for bathing, washing of clothes, air coolers, air conditioning, lawn watering, gardening, etc.

Similarly the requirement of water is more in summer than in winter. Further in extremely cold climates water may be wasted due to taps being always kept open to avoid freezing of pipes, which may result in increased rate of consumption

### **Cost of Water:**

The rate at which water is supplied to the consumers may also affect the rate of demand of water. If the rates at which water is supplied are high, lesser quantity of water may be consumed by the people, and vice versa. However, the general observation is that the consumption of water reduces only slightly as the cost is increased.

### **Number of Commercial Establishments and Industries:**

In general the presence of commercial and other establishments and industries in a town or city would increase the rate of demand of water. The rate of demand of water would further increase with the increase in the number of such

establishments and industries. However, if the industries develop their own water supply system, then there may not be much increase in the rate of demand of water for the public water supply system.

### **Economic Status of Consumers:**

The consumption rate of water is directly dependent upon the economic status of the consumers. Rich and upper class people generally consume more water due to their better standard of living. On the other hand middle class people have average rate of consumption of water while the poor slum dwellers have a much lower rate of water consumption.

### **Methods of forecasting population**

The following are the standard methods by which the forecasting of population is done:

1. Arithmetical Increase Method.
2. Geometrical Increase Method.
3. Incremental Increase Method
4. Decreasing Rate Method
5. Simple Graphical Method
6. Comparative Graphical Method
7. Master Plan Method
8. The Logistic Curve Method

9. The Apportionment Method.

***Arithmetical Increase Method:***

This method is based on the assumption that the population is increasing at a constant rate. The rate of change of population with time is constant.

i.e.  $dp/dt = C$  (a constant)

integrating  $P_2 - P_1 = C(t_2 - t_1)$ ..... (5.5)

Where  $P_1$  = Population at the time  $t_1$  first census

$P_2$  = Population at the time  $t_2$  last available census

The value of constant  $C$  is determined.

Now the population after  $n$  decade can be determined by the formula

$$P_n = P + n \cdot C$$

**Example 1:**

<i>Year</i>	<i>Population</i>
1940	8,000
1950	12,000
1960	17,000
1970	22,500

Calculate the probable population in the year 1980, 1990 and 2000.

<i>Year</i>	<i>Population</i>	<i>Increase in Population</i>
1940	8,000	4000 5000 5500
1950	12,000	
1960	17,000	
1970	22,500	
	Total	14,500
	Average Inverse	4,833

*Solution.*

<i>Year</i>	<i>Population</i>
1980	$22,500 + 1 \times 4833 = 27,333$
1990	$27333 + 1 \times 4833 = 32,166$
2000	$32166 + 1 \times 4833 = 36,999$

### ***Geometrical Increase Method:***

This method is based on the assumption that the percentage increase in population from decade to decade remains constant. In this method the average percentage of growth of last few decades is determined; the population forecasting is done on the basis that percentage increase per decade will be the same.

**If the present population is P and the average percentage growth is  $I_G$  the population at the end of n decade will be:**

$$P_n = P \left( 1 + \frac{I_G}{100} \right)^n$$

**Example 2:**

Forecast the population of example 1 by means of geometrical increase me

<i>Year</i>	<i>Population</i>	<i>Increase in Population</i>	<i>Percentage increase in Population</i>
1940	8,000	—	
1950	12,000	4,000	$\frac{4000}{8000} \times 100 = 50.0 \%$
1960	17,000	5,000	$\frac{5000}{12000} \times 100 = 41.7 \%$
1970	22,500	5,500	$\frac{5500}{17000} \times 100 = 32.4 \%$
Total		14,500	124.1
Average per decade		4,833	41.37

**The population at the end of various decades shall be as follows:**

<i>Year</i>	<i>Expected Population</i>
1980	$22,500 + \frac{41.37}{100} \times 22,500 = 31,808$
1990	$31,808 + \frac{41.37}{100} \times 31,808 = 44,967$
2000	$44,967 + \frac{41.37}{100} \times 44,967 = 63,570$

***Incremental Increase Method:***

This method is improvement over the above two methods. The average increase in the population is determined by the arithmetical method and to this is added the average of the net incremental increase once for each future decade.

P is the present population,  $l_a$  = Average Arithmetical increase, and  $l_c$  is the average incremental increase, then population after 'n' decade will be

$$P_n = P + n(l_a + l_c)$$

Forecast the population of example 1, by means of incremental increase method.

<i>Year</i>	<i>Population</i>	<i>Increase in Population</i>	<i>Incremental increase i.e. increment on the increase</i>
1940	8,000	—	—
1950	12,000	4,000	—
1960	17,000	5,000	+ 1000
1970	22,500	5,500	+ 0500
	Total	14,500	+ 1500
	Average	4,833	(+ ) 750

**The population at the end of various decades shall be as follows:**

In the year 1980,

$$P_{1980} = 22,500 + 1 \times (4833 + 750)$$

$$P_{1980} = 28,083$$

$$P_{1990} = 28,083 + (4833 + 750) \times 1$$

$$P_{1990} = 33,666$$

$$\text{and } P_{2000} = 33,666 + (4833 + 750)$$

$$P_{2000} = 39249$$

### ***Decrease Rate of Growth Method or Decreasing Rate Method:***

It has been seen that all life grow within limited space. If the complete growth of a very old city is plotted, it will be seen that the curve has S-shape, which indicates that early growth takes place at an increasing rate, latter growth is at a decreasing rate which indicates that saturation limit is reached.

In this method, the average decrease in the percentage increase is worked out and is then subtracted from the latest percentage increase for each successive decade.

### ***Simple Graphical Method:***

In this method the populations of last few decades are correctly plotted to a suitable scale on the graph with respect to decade. The curve is smoothly extended

to forecast the future population. The graph of present city is plotted from the beginning and it will show the growth curve. shows the typical growth curve of a city of example.

### ***Comparative Graphical Method:***

In this method, the cities having conditions and characteristics similar to the city whose future population is to be estimated are first of all selected. It is then assumed that the city under consideration will develop as the selected similar cities have developed in the past. This method has a logical background, and if statistics of development of similar cities are available quite precise and reliable results can be obtained.

Now, Suppose it is required to estimate the population of the city A at the end of year 2010. And let the available data show that this city A has reached the present population of 42500 in the year 1970. Then the available data of similar cities Band C is analyzed. Let it be found that city B has reached 42500 in the year 1940 then its curve is plotted beyond the year 1940 onward.

## **IMPURITIES IN WATER**

The impurities in water are broadly listed as follows:-

- a) Suspended Impurities
- b) Colloidal Impurities
- c) Dissolved Impurities

### **Suspended Impurities**

- Water may contain suspended Impurities such as clay, mud ,algae, fungi, organic and inorganic matters, industrial waste etc.

- These impurities are dispersion of solid particles that are large enough to be removed by filtration on the surface.
- These all impurities are macroscopic and cause turbidity in the water .
- The size of the particles ranges from 0 to 10 to the power 10.

### Colloidal Impurities

- Colloidal particles such as Crystals, Glasses, Gels & silica may present in water.
- These are charged particles
- Size of colloidal particles is very small.
- Such impurities never settles down and they remain in motion.

### Dissolved Impurities

- Solids , liquids and gases are dissolved in natural waters.
- Some impurities are dissolved in water when it moves over the rocks , soils etc.
- This dissolved impurities may contain organic compounds, inorganic salts and gases etc

### **Harmful Effects of Impurities**

- Bacteria's – cause diseases
- Algae, Protozoa- cause odour , turbidity and colour
- Clay, Silt- cause turbidity
- Calcium and magnesium (carbonate – causes hardness and alkalinity)

(Sulphate - causes hardness

(Bicarbonates - causes alkalinity and hardness

- Sodium (chloride- cause taste and salinity

(Manganese – causes black or brown in colour

(Iron Oxide- cause taste , corrosiveness, hardness and colour

- Metal (lead – cause lead poisoning

(Arsenic- cause poisoning

(Oxygen- Corrode the metals

(Carbon dioxide- Cause acidity and Corrode the metals

- Gases (Hydrogen sulphate- cause rotten egg, odour acidity and corrode the metals

## **Water Quality**

The raw or treated water is analysed by testing their physical, chemical and bacteriological characteristics:

**Physical Characteristics:** indicate properties detectable by the senses

- Turbidity
- Colour

- Taste and Odour
- Temperature

**Chemical Characteristics:** determine the amounts of mineral and organic substances that affect water quality.

- pH
- Acidity
- Alkalinity
- Hardness
- Chlorides
- Sulphates
- Iron
- Solids
- Nitrates

**Bacteriological Characteristics:** show the presence of bacteria, characteristic of faecal pollution.

Bacterial examination of water is very important, since it indicates the degree of pollution. Water polluted by sewage contain one or more species of disease producing pathogenic bacteria. Pathogenic organisms cause water borne diseases, and many non pathogenic bacteria such as E.Coli, a member of coliform group, also live in the intestinal tract of human beings. Coliform itself is not a harmful group but it has more resistance to adverse condition than any other group. So, if it is ensured to minimize the number of coliforms, the harmful species will be very less. So, coliform group serves as indicator of contamination of water with sewage and presence of pathogens. The methods to

estimate the bacterial quality of water are: Standard Plate Count Test Most Probable Number Membrane Filter Technique.

### Indian Standards for drinking water

Parameter	Desirable-Tolerable	If no alternative source available, limit extended upto
<b>Physical</b>		
Turbidity	< 10	25
Colour	< 10	50
Taste and Odour	Un-objectionable	Un-objectionable
<b>Chemical</b>		
pH	7.0-8.5	6.5-9.2
Total Dissolved Solids mg/l	500-1500	3000
Total Hardness mg/l (as CaCO <sub>3</sub> )	200-300	600
Chlorides mg/l		

(as Cl)		200-250	1000
Sulphates	mg/l	150-200	400
(as SO4)			
Fluorides	mg/l	0.6-1.2	1.5
(as F )			
Nitrates	mg/l (as		45
NO3)		45	
Calcium	mg/l (as		200
Ca)		75	
Iron	mg/l (as Fe )	0.1-0.3	1.0

## CHAPTER 2

### SOURCES AND CONVEYANCE OF WATER

#### SOURCES OF WATER

There are 2 important Sources of Water

- i. Surface Sources
- ii. Underground Sources

#### Surface or Direct Sources of Water

This type includes the following

- i. Rivers
- ii. Streams
- iii. Lakes
- iv. Reservoirs

#### *Rivers*

Rivers are formed along more or less defined channels to drain from land all the water received in the form of rainfall and melting of snow from high altitudes. Their development is the work of ages.

#### *Streams*

Rainwater infiltrates into the soil and subsequently joins the ground water storage. When the natural relief is such that the ground surface at any point falls below the top surface of groundwater reservoir then there exists greater hydrostatic pressure in the soil mass. The groundwater under pressure then finds way through the soil into the depression forming a, stream.

***Lakes:***

Rainwater in excess of all sorts of losses runs off the surface of the earth. When this water is caught in very big natural depression a lake is formed. Lakes also derive water from groundwater. This water is also available for use whenever required.

***Reservoirs:***

When some obstruction like a dam or a weir is constructed at the narrowest point of a valley to store large quantity of water behind it reservoir or artificial storage is formed. This water can be very conveniently used for various purposes with provision of suitable hydraulic structures.

**Underground or Indirect Sources of Water:**

the following sources can be listed:-

- i. Open Wells
- ii. Tube Wells
- iii. Artesian Wells
- iv. Infiltration Gallery
- v. Infiltration Wells

***Open Wells:***

If it is ascertained that sufficient water is entrapped in some water bearing stratum below the ground surface, the entrapped water can be made available for use. A hole is sunk into the ground till it reaches such a depth as to hold sufficient water for use. Water should be available at lesser depth for economic justification.

### ***Tube Wells:***

If there are water bearing rocks or soil layers alternate to impervious layers or water bearing strata of indefinite extent then a metal tube with suitable perforations may be sunk in the ground to derive the water for use.

### ***Artesian Wells:***

When a permeable stratum is confined between impervious strata at the top and bottom artesian condition exists. The outcrop of the permeable stratum should be at a height enough to produce sufficient hydrostatic pressure on the water at lower points.

### ***Infiltration Gallery:***

When water can be obtained within a reasonable distance below ground level, for example, below the river bed, horizontal porous pipes with open joints can be laid under the ground. It is apparent that a very large proportion of the groundwater will be intercepted by galleries than by a vertical well.

### ***Infiltration Wells:***

Sometimes water can be made available by sinking infiltration wells in the porous soil, for example, in the dry bed of a river. The infiltration well can be joined to vertical collecting wells or jack wells sunk on the bank of the river by means of horizontal underground porous pipeline. It intercepts water also and is called Infiltration gallery. Thus it can be recognized that infiltration wells and galleries supplement each other.

### **Yield of Wells**

It is well known that under the favourable condition water tries to maintain its own level. Hence, it is obvious that the level of water in a well approximately indicates

the level of water table under normal conditions of no withdrawal. As the water is pumped out or withdrawn from the well the level of water in the well falls more quickly than the ground water level and consequently it forms a cone of depression. The difference of level of water table and the water level in the well now is called a head of depression.

Actually under this head water percolates into the well through soil pores. Naturally when depression head is more the rate of water contribution to the well will also be more. If the depression head goes on increasing, due to continued water withdrawal from the well then a time may come when the increased velocity will dislodge the soil particles. At this stage the percolating water brings soil particles with it in the well.

The yield of open well can be determined by any one of the two methods, namely, pumping test and recuperation test.

### ***Pumping Test***

In this method water is withdrawn from the well freely till a critical depression head or a safe maximum head is created. Once this stage is reached the rate of pumping is so adjusted as to maintain the constant water level in the well. Thus the depression head remains constant. Naturally at this stage the rate at which water is pumped out of the well will be equal to the rate at which water percolates into the well. This rate is expressed in  $\text{m}^3/\text{hr}$  or  $\text{lt}/\text{min}$  and will be obviously the yield of the well.

### **Specific Yield of Wells**

Rate of water percolation in the well or yield of a well in  $\text{m}^3/\text{hr}$  under a head of one metre is called the specific yield of the well. From the above definition it is clear

that the specific yield depends on: (i) position of the water-table, (ii) permeability and porosity of the soil formation, (iii) the rate of water withdrawal from the well, and (iv) quantity of water storage in the well. Specific yield of the well is also called specific capacity of the well.

$$K = 2.303 [A/T \log H_1/H_2]$$

Where K is specific yield of a well in m<sup>3</sup>/hr under depression head of one metre.

A is area of well in plan in m<sup>2</sup>.

T is total time of recuperation to bring water level from depth H<sub>1</sub> to H<sub>2</sub>

### **INTAKE STRUCTURE FOR WATER SUPPLY**

Intake structures are the construction, used for storing the water, from surface sources (river, reservoir and lakes) and conveying it further to treatment plant.

An intake may be nearer to water sources such as river, lake, etc.

An intake is a structure which is constructed across the water source so as to permit the safe withdrawal of water from the water source. The structure may be stone, brick, RCC, or Concrete block masonry

### **Factors governing location of an intake**

1. The location of intake structure should be nearer to the treatment plant, in order to reduce the cost of conveyance water.
2. The location of the intake should be selected in a place, where there is the less impurities presence.

3. The intake should be selected at a place from where the water can be taken during driest season of the year also.
4. The intake location should have the possibility for future expansion and addition without much increase in cost.
5. The intake should not be located at the downstream of the disposal point of sewage.
6. It should be located in such a way that, it should not be affected by heavy flood and the flood should not enter through the intake.
7. The intake should not be located near the navigation channels such as Harbour etc.
8. It should not be interference with river traffic if any.

### **Type of intake structures**

1. Simple submerged Intake
2. Intake Tower or River Intake Structures
  - a) Wet Intake Towers
  - b) Dry Intake Towers
3. Reservoir Intake
4. Canal Intake Structures

## ***SIMPLE SUBMERGED INTAKE***

- A submerged intake structures consists of simple concrete block or a rock filled timber crib supporting the starting end of the withdrawal pipe.
- The withdrawal pipes are generally taken up to the sump well at shore from where the water is lifted by pumps.
- The intake opening is generally covered by screen so as to prevent the entry of debris, ice etc., into the withdrawal pipe.
- In case of lakes where silt tends to settle down, the intake opening is generally kept about 2 to 2.5 m above the bottom of the lake and thus to avoid the entry of silt and sediment.
- Such intake structures should be placed in streams or intakes at a place where they may not get buried under sediment and where there are deep water.
- These are widely used intakes for small water supply projects drawing water from streams and lakes having relatively little change in water surface elevation throughout the year.

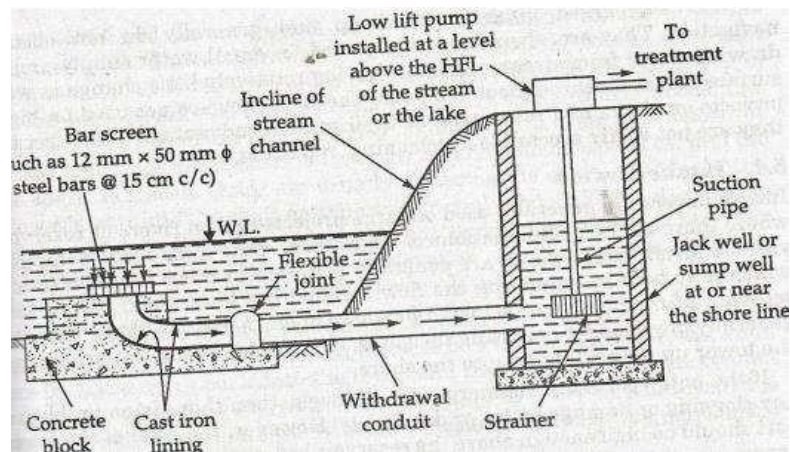

## ***INTAKE TOWERS OR RIVER INTAKE STRUCTURES***

- Intake towers are generally used on large projects and on rivers or reservoirs where there is large fluctuation of water level.
- Gate controlled openings at various levels called ports are generally provided in these concrete towers which may help in regulating the flow through the towers and permit some selection of the quality of water to be withdrawn.
- Accesses to these towers are generally provided for operating the gates, etc., by means of a foot bridge from the tower up to the dam or up to the shore.

### **Types of Intake Towers (river)**

- a) Wet intake Towers
- b) Dry Intake Towers

### **Wet Intake Tower**

- a) The wet intake is that type of intake tower in which the water level is practically the same as the level of source of supply.
- b) It is sometimes known as JACK Well and it is most commonly used.
- c) It

circular  
up to the  
has a

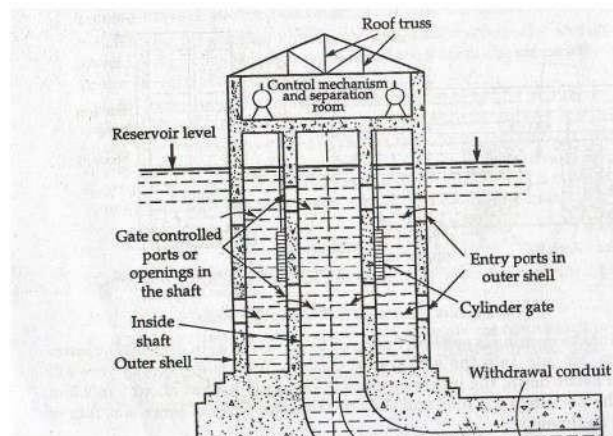

consists of a concrete  
shell filled with water  
reservoir level and  
vertical inside shaft

which is connected to the withdrawal pipe.

### **Dry Intake Tower**

- a) The essential difference between a dry intake and wet intake is that in a wet intake the water enters from the entry ports in to the intake and then it enters in to the conduit pipe through separate gate controlled openings whereas in a dry intake water is directly drawn in to the withdrawal pipe through the gate entry openings.
- b) A dry intake will therefore have no water inside the intake if its gates are closed whereas the wet intake will be full of water even if its gates are closed.

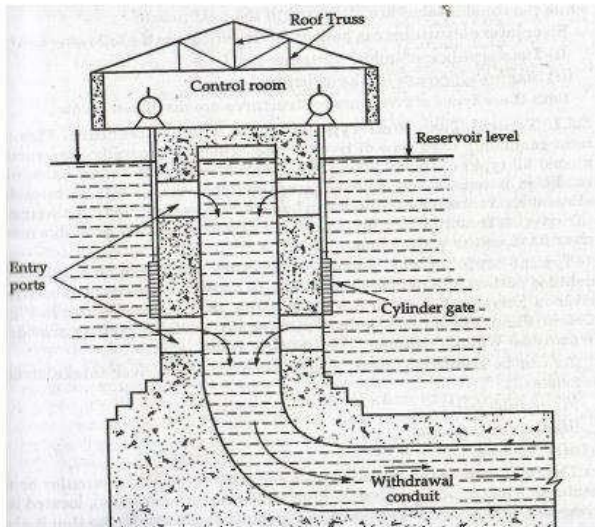

## ***RESERVOIR INTAKES***

- When the flow in the river is not get guaranteed throught the year a dam is constructed across it to store water in the reservoir so formed.
- The reservoir intakes are practically similar to the river intake except that these are located near the upstream face of the Dam where maximum depth of water is available.
- The access to intake is provided through a foot bridge.
- The water level will be the same as the reservoir level.

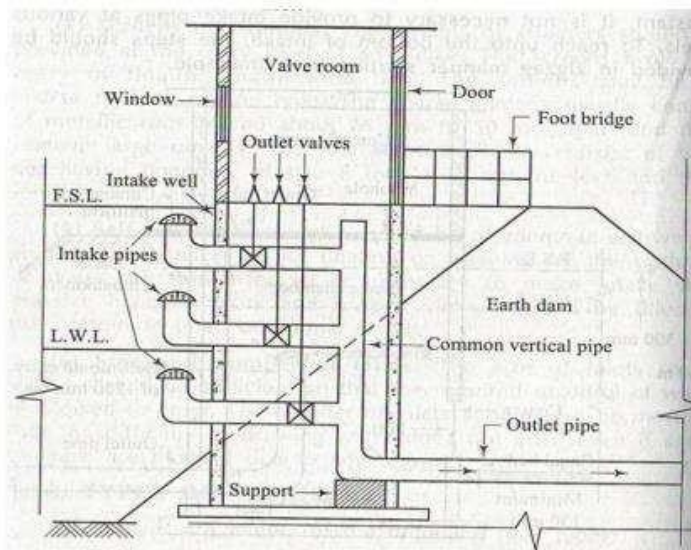

## ***CANAL INTAKE***

- In canal intake structure, the intake well is generally located in the bank of the canal and water enters the chamber through the inlet pipe. The inlet pipe is covered with a fine screen.
- The top of the screen is generally provided at minimum water level in the canal and bottom is about 0.15 m above the canal bed to avoid entry of bed load.
- The inlet end is of bell mouth shape with perforation of fine screen on its surface.
- The flow velocity through the out let is generally 1.5 m/sec, and this helps in determining the area and diameter at the withdrawal pipe.
- The area of the coarse screen is designed by limiting the flow velocity to as low as 0.15m/sec.
- The flow velocity through the bell mouth is limited to about 0.3 m/sec.

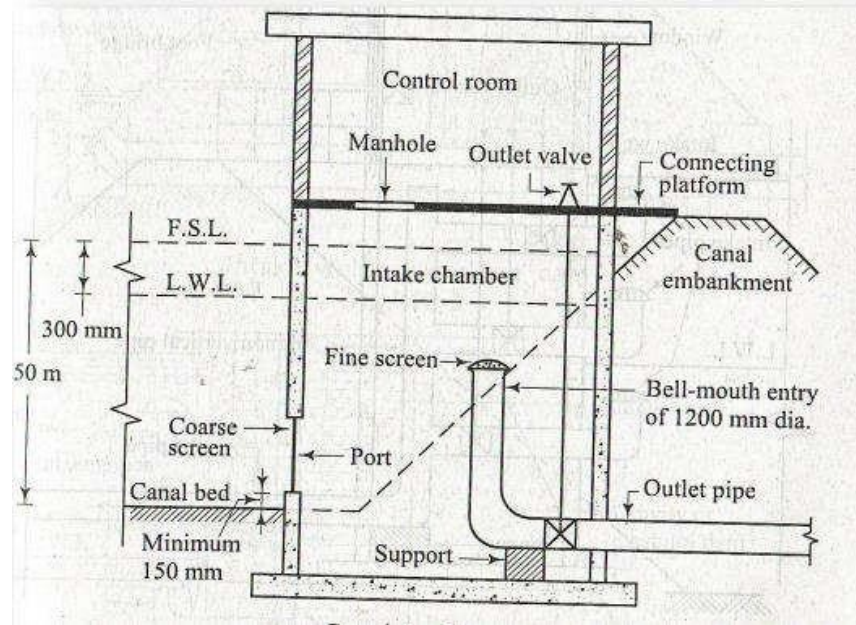

## VARIOUS MATERIALS USED FOR PIPES

1. Asbestos cement pipes
2. Cast-iron Pipes
3. Cement concrete pipes
4. Copper pipes
5. Galvanised pipes
6. Lead pipes
7. Plastic pipes
8. Steel pipes
9. Steel pipes
10. Wood pipes

### 1. Asbestos cement pipe

- Made from mixture of Asbestos fibre and cement.
- Convey water under low pressure.

#### **ADVANTAGES:-**

- Inside surface- Very smooth
- Joining- Very good, flexible, easily
- Light in weight, easy to handle & transport
- Very suitable for distribution pipes of small size

#### **DISADVANTAGES:-**

- Brittle; cannot withstand impact forces
- Not durable
- Cannot be laid in exposed places
- Can be used only for very low pressure.

## **2. Cast iron pipes**

- Mainly used for conveyance of water.
- Joined by bell and spigot (or) Expansion joint.
- The spigot is of smaller diameter and is inserted to the larger diameter bell end. Expansion Joint: Severe change of temperatures
- A rubber gasket is inserted between the spigot and the bell end.
- Flanged joint: Water at high pressure. At a wide flange will be provided which are bolted together.
- They are manufactured by pig-iron and given some suitable treatments

#### **ADVANTAGES**

- The cost is moderate
- Easy to join
- Not subjected to corrosion
- Strong & Durable

### **DISADVANTAGES**

- The breakage of these pipes is large.
- Carrying capacity decreases with the increases in life
- Not used for pressure greater than  $0.7 \text{ N/mm}^2$
- Heavier & Uneconomical- Size beyond 1200 mm dia.

### **3. Cement concrete pipes Plain (or) Reinforced (or) Pre stressed pipes**

- Plain – 15 m , RCC – 75 m and High head – pre stressed.
- Reinforcement in the form of links or hooks and longitudinal bars
- Mould - Hume pipe (or) Spun concrete pipes

### **ADVANTAGES**

- Inside Surface – Very smooth
- Maintenance cost is low
- Pipes can be cast at site and can be transported.
- Does not require expansion joint
- No danger of rusting  $\Rightarrow$  & incrustation

### **4. Copper pipes**

- Widely used for service connections

### **ADVANTAGES**

- Cheap, light in weight and easy to handle and transport.
- Easy to join

## **DISADVANTAGES**

- Liable for incrustation & easily affected by acidic or alkaline water.
- The useful life of pipe is short about 7 to 10 years.

### **5. Lead pipes**

- Not adopted for conveyance of water due to lead poisoning
- It can be easily bent.
- Apparatus required for alum & chlorine discharge- can not water.
- It can be bent due to hot water.

### **6. Plastic pipes**

- LDPE- Low Density Poly Ethylene Pipes- Flexible
- Strong in resisting acids
- PVC- Poly Vinyl Chloride Pipes three times as rigid as poly ethylene pipe

## **ADVANTAGES**

- Freedom from damage due to thawing & freezing Pipes are very cheap
- Durable & Hydraulic resistant Free from corrosion
- Good electric insulator
- Light in weight easy to bend

## **DISADVANTAGES**

- Co-efficient of expansion for plastic is high
- Difficult to obtain the plastic pipes of uniform compositions
- Less restraint to heat

- Some type- impart to the taste of water.

## **7. Steel pipes**

- Mild steel is used for steel pipes
- Joints – Riveted or Welded
- Generally used for more than 1200 mm dia
- Inside generally galvanized.

### **ADVANTAGES**

- Available in long length- No of joints less
- Cheap & Best in cost
- Durable & Strong
- Flexible to some extent & laid easily on curves
- Light in weight & easy to transport

### **DISADVANTAGES**

- Maintenance cost is high
- Rust attack due to alkali water
- Require more time for repairing
- Deform shapes under combined action of internal and external load.

## **8. Wood pipes**

- Usually prepared of staves or planks wood held together by steel bands.
- Light in weight cannot bear higher pressure
- Rarely adopted for conveyance of water.

## 9. Wrought Iron pipe

- Light in weight can be easily cut threaded and worked.
- Costly and Less durable.
- Not generally used in water conveyance system.

## JOINTS IN PIPE

Pipe joints are the assemblies used to connect one pipe with other without any leakage or other losses.

## CLASSIFICATION

### 1. *Based on the Rigidity & Flexibility*

- a) Rigid Joint
- b) Semi Rigid Joint
- c) Flexible Joint

### 2. *Based on Functions & location*

- a) Spigot and Socket Joint
- b) Expansion Joint
- c) Flanged Joint
- d) Screwed Joint

## **Rigid joints**

- Rigid Joints are those which admit no movement at all and comprise flanged, welded and turned and bored joint.
- Flanged joints require perfect alignment and close fittings and are frequently used where a longitudinal thrust must be taken such as at the valves and meters.
- The gasket used between the flanges of pipes shall be compressed fibre board or natural or synthetic rubber.

- Welded joints produce a continuous line of pipe with the advantage that interior and exterior coatings can be made properly and are not subsequently disrupted by the movement of joints.

### **Semi rigid joints**

- A semi rigid joint allows partial movement due to vibration etc.
- The socketed end of the pipe should be kept against the flow of water and the spigot end of the other pipe is inserted in to this socket .
- A rope is then placed at the outer end of the socket and is made by tight fit by applying wet clay leaving two holes for the escape of the entrapped air inside.

### **Flexible joints**

- Flexible joints are used where rigidity is undesirable such as filling of granular and when two sections cannot be welded.
- They comprise mainly mechanical and rubber ring joints which permit some degree of deflection at each joint and are therefore able to withstand vibration and movements.
- In the rubber jointing special type of rubber gasket are used to connect cast iron pipe which are cast with a special type of spigot.
- Rubber joint is to be preferred to lead joining.

### **Spigot & socket joint**

- This is mostly suitable for cast iron pipes
- This type of joint is connected by inserting the spigot end of one pipe in to the socket or bell end of the other.
- The connecting procedure includes; wrapping of jute around the spigot before inserting it in to the socket.

- Then in the remaining space or gap between spigot and socket is filled by molten lead.
- Cooling time will be given for the solidification of molten lead.
- The flexibility of this joint is less and need skilled labour.

### **Expansion joint**

- The main advantage of the expansion joints is its flexibility.
- In some cases the pipes are laid over the ground and exposed to the atmosphere.
- Due to thermal stresses the pipe will tend to expand and contract which ultimately results in the formation of cracks in the external surface of the pipe and leak in the joints.
- In this type of joint the socket end is connected rigidly to an annular ring which can freely over the spigot joint.
- The provision of gasket will aid the pipe movement at the time of expansion due to thermal stress.

### **Flanged joint**

- This type of joint mostly used for temporary pipe network.
- The pipe has flanges at both the ends .
- This ends are connected by bolts and nut or welding.
- During the connection process a rubber gasket is placed between the two ends which will prevent leakage.
- This joint is commonly used in plumbing station boiler house etc.

- But if this joint is used in steel pipe it will be better to connect by nuts and bolt) rather by other connection.

### **Screwed joint**

- The screwed joints are usually adopted when the pipe diameter is less.
- In this joint the ends of the pipes are threaded outside, while socket or coupling has threads on both the ends of the pipe to join them.
- For making water tight zinc paint or hemp yarn should be placed in the threads of the pipe, before screwing socket over it

## **CHAPTER 3**

### **TREATMENT OF WATER**

#### **Water Treatment**

- Water Treatment is the process of removing contaminants from waste water and household water.
- Its objective is to produce an environmentally safe fluid waste stream and a solid waste suitable for disposal and reuse.

#### **Why Water Treatment is needed?**

- To kill all the pathogenic germs, which are harmful to the human health.
- To remove the unpleasant & objectionable taste and odours from the water.
- To remove dissolved gases, colour of the water.
- To make fit for the domestic, industrial and commercial uses.
- To remove micro-organisms & colloidal matters.

#### **Layout of water treatment system**

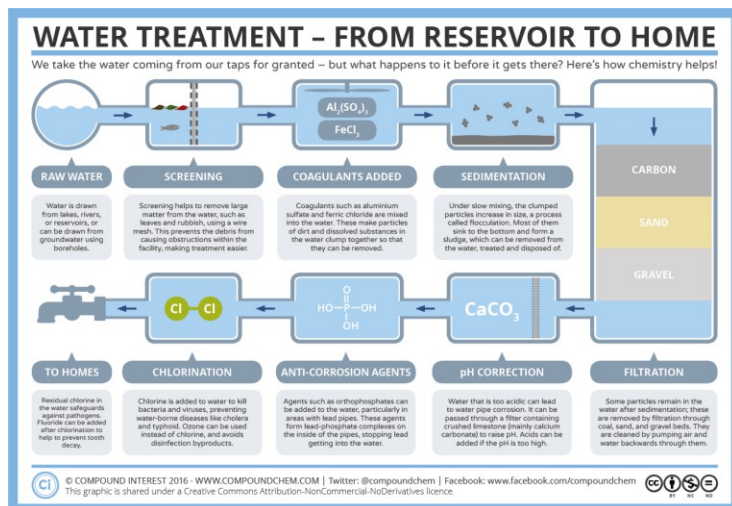

The water treatment process are:-

- Screening
- Aeration
- Plain Sedimentation
- Sedimentation with Coagulation
- Filtration
- Disinfection
- Chlorination
- Softening Of water

## Aeration

Wastewater aeration is the process of adding air into wastewater to allow aerobic bio-degradation of the pollutant components. It is an integral part of most biological wastewater treatment systems. Unlike chemical treatment which uses

chemicals to react and stabilize contaminants in the wastewater stream, biological treatment uses microorganisms that occur naturally in wastewater to degrade wastewater contaminants.

### ***When is Aeration Used?***

In municipal and industrial wastewater treatment, aeration is part of the stage known as the secondary treatment process. The activated sludge process is the most common option in secondary treatment. Aeration in an activated sludge process is based on pumping air into a tank, which promotes the microbial growth in the wastewater. The microbes feed on the organic material, forming flocks which can easily settle out. After settling in a separate settling tank, bacteria forming the "**activated sludge**" flocks are continually recirculated back to the aeration basin to increase the rate of decomposition.

### ***How does Aeration Work?***

Aeration provides oxygen to bacteria for treating and stabilizing the wastewater. Oxygen is needed by the bacteria to allow biodegradation to occur. The supplied oxygen is utilised by bacteria in the wastewater to break down the organic matter containing carbon to form carbon dioxide and water. Without the presence of sufficient oxygen, bacteria are not able to biodegrade the incoming organic matter in a reasonable time. In the absence of dissolved oxygen, degradation must occur under septic conditions which are slow, odorous, and yield incomplete conversions of pollutants. Under septic conditions, some of the biological process convert hydrogen and sulphur to form hydrogen sulphide and transform carbon into methane. Other carbon will be converted to organic acids that create low pH

conditions in the basin and make the water more difficult to treat and promote odour formation. Bio-degradation of organic matter in the absence of oxygen is a very slow biological process.

### ***Why is Aeration Important for Wastewater Treatment?***

Aeration is the most critical component of a treatment system using the activated sludge process. A well designed aeration system has a direct impact on the level of wastewater treatment it achieves. An ample and evenly distributed oxygen supply in an aeration system is the key to rapid, economically-viable, and effective wastewater treatment.

### **Sedimentation**

Sedimentation is a common way of treating water. It is a process that removes solids that float and settle in the water. The process relies on the use of sedimentation tanks that remove larger solids. Subsequent treatment processes may be used after sedimentation. It is important to understand how sedimentation is used in the treatment of drinking water and wastewater.

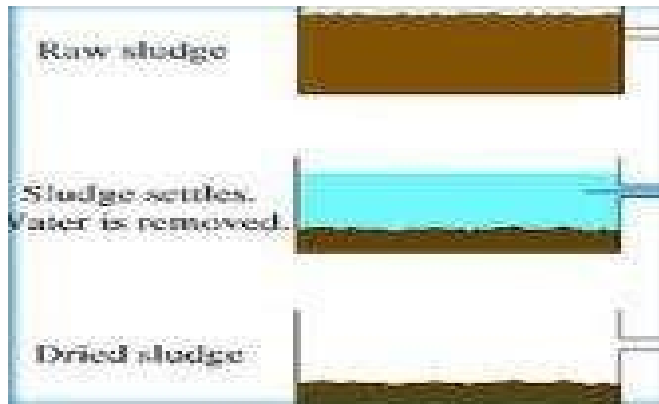

### **What is sedimentation in water treatment?**

Sedimentation is one of the methods that municipalities use for treating water. It is a physical water treatment process. Gravity is used to remove suspended solids from water.

The effectiveness depends on the size and weight of the particles. Suspended solids that have a specific gravity similar to water remain suspended while heavier particles settle. The sedimentation process in wastewater treatment usually occurs in tanks of various shapes.

### **What are the advantages of sedimentation in wastewater treatment?**

Sedimentation of water is one of the most basic processes of purifying water, making it a process that is commonly used and understood throughout the world. It may be used as a preliminary step in some water treatment processes. It provides the following benefits to municipalities that employ it:

- Fewer chemicals are required for subsequent water treatment.
- It makes any subsequent process easier.
- The cost is lower than some other methods.
- There is less variation in the quality of water that goes through the process.

## **What is the sedimentation process in wastewater treatment?**

A sedimentation tank in wastewater treatment removes particles from the water. The accumulated solids, or sludge, form at the bottom of the sedimentation tank and are removed periodically. Coagulants are typically added to the water before sedimentation to aid in the settling process. After sedimentation, there are often other treatment steps.

When sedimentation is used to treat wastewater, this primary step is followed by secondary treatment, such as a trickling filter, activated sludge or another purification process that is used to remove soluble impurities with bacteria.

### **Purpose of sedimentation**

- To remove coarse dispersed phase.
- To remove coagulated and flocculated impurities.
- To remove precipitated impurities after chemical treatment.
- To settle the sludge (biomass) after activated sludge process

### **Principle of Sedimentation**

- Suspended solids present in water having specific gravity greater than that of water tend to settle down by gravity as soon as the turbulence is retarded by offering storage.

- Inorganic suspended solids having specific gravity of about 2.65; and organic suspended solids having specific gravity of about 1.04
- The particles having specific gravity of about 1.20 or so readily settle down at the bottom of tank.
- This phenomenon of settling down of particles at the bottom of sedimentation tank is known as hydraulic subsidence and every particle has its own hydraulic settling value which will cause its hydraulic subsidence.

### **Types of sedimentation**

There are 2 types of sedimentation:-

1. Plain sedimentation
2. Sedimentation with coagulation

### **Plain Sedimentation**

- It is process of settling down of solids and impurities in the raw water to the bottom of sedimentation basin by natural gravity force alone, no chemical is added.
- This method is very cheaper and mostly used in all filtration and purification system of water.

### **Zones in sedimentation tank**

- There are 4 major zones in the sedimentation tanks:-

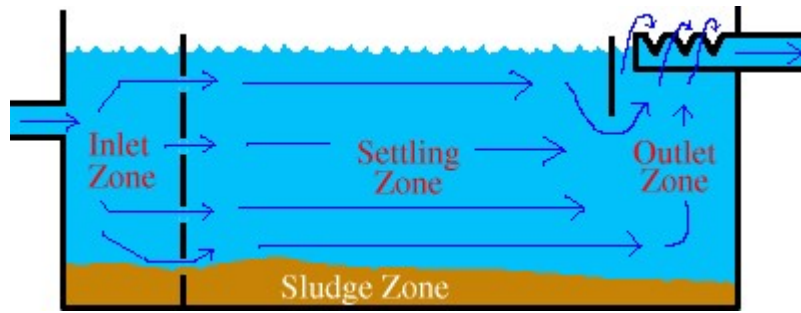

**Sedimentation basins** have 4 zones

1. The Inlet zone,
2. The Settling zone,
3. The Sludge zone, and
4. The Outlet zone.

### ***Inlet Zone***

- The two primary purposes of the inlet zone of a sedimentation basin are to distribute the water and to control the water's velocity as it enters the basin.
- In addition, inlet devices act to prevent turbulence of the water.
- The incoming flow in a sedimentation basin must be evenly distributed across the width of the basin to prevent short-circuiting. S
- hort-circuiting is a problematic circumstance in which water bypasses the normal flow path through the basin and reaches the outlet in less than the normal detention time. In addition to preventing short-circuiting, inlets control the velocity of the incoming flow.

- If the water velocity is greater than 0.15 m/ sec, then flocs in the water will break up due to agitation of the water. Breakup of flocs in the sedimentation basin will make settling much less efficient.
- The stilling wall, also known as a perforated baffle wall, spans the entire basin from top to bottom and from side to side.
- Water leaves the inlet and enters the settling zone of the sedimentation basin by flowing through the holes evenly spaced across the stilling wall.
- The second type of inlet allows water to enter the basin by first flowing through the holes evenly spaced across the bottom of the channel and then by flowing under the baffle in front of the channel. The combination of channel and baffle serves to evenly distribute the incoming water.

### *Settling Zone*

- After passing through the inlet zone, water enters the settling zone where water velocity is greatly reduced.
- This is where the bulk of settling occurs and this zone will make up the largest volume of the sedimentation basin.
- For optimal performance, the settling zone requires a slow, even flow of water. The settling zone may be simply a large area of open water.

### *Outlet Zone*

- The outlet zone controls the amount of water flowing out of the sedimentation basin. Like the inlet zone, the outlet zone is designed to prevent short-circuiting of water in the basin. In addition, a good outlet will ensure that only well-settled water leaves the basin and enters the filter.

- The outlet in the form of overflow weir can also be used to control the water level in the basin. The best quality water is usually found at the very top of the sedimentation basin, so outlets are usually designed to skim this water off the sedimentation basin.
- A typical outlet zone begins with a baffle in front of the effluent.
- This baffle prevents floating material from escaping the sedimentation basin and clogging the filters. After the baffle, the effluent structure, which usually consists of a launder, weirs, and effluent piping, is located.
- The primary component of the effluent structure is the effluent launder, a trough which collects the water flowing out of the sedimentation basin and directs it to the effluent piping.
- The sides of a launder typically have weirs attached.
- Weirs are walls preventing water from flowing uncontrolled into the launder. The weirs serve to skim the water evenly off the tank.
- A weir usually has notches, holes, or slits along its length.
- These holes allow water to flow into the weir.
- The most common type is the V -shaped notch shown on the picture above which allows only the top few centimeters of water to flow out of the sedimentation basin.
- Conversely, the weir may have slits cut vertically along its length, an arrangement which allows for more variation of operational water level in the sedimentation basin. Water flows over or through the holes in the weirs and into the launder.
- Then the launder channels the water to the outlet pipe.
- This pipe carries water away from the sedimentation basin and to the next step in the treatment process.

- The effluent structure may be located at the end of a rectangular sedimentation basin or around the edges of a circular clarifier.
- Alternatively, the effluent may consist of finger weirs an arrangement of launders which extend out into the settling basin as shown below.

### ***Sludge Zone***

- The sludge zone is found across the bottom of the sedimentation basin where the sludge is collected temporarily .
- Velocity in this zone should be very slow to prevent resuspension of sludge.
- A drain at the bottom of the basin allows the sludge to be easily removed from the tank. The tank bottom should slope toward the drains to further facilitate sludge removal.
- In some plants, sludge removal is achieved continuously using automated equipment.
- In other plants, sludge must be removed manually.

### **Types of sedimentation tanks**

#### **i) Based on methods of operation**

- *Intermittent type* - The intermittent type tank are those which store water for a certain period and keep it on completely rest.
- *Continuous type*- In continuous type tank , the flow velocity is only reduced and water is not brought to complete rest .

#### **ii) Based on shape**

Rectangular tank

Circular tank

Square tank

## Rectangular Tanks



- These are most commonly used for primary sedimentation, since they
- Occupy less space than circular tanks.
- They can be economically built side-by-side with common walls.
- Length ranges 15 to 100m and width from 3 to 24m (length/ width ratio 3:1 to 5:1)
- The maximum forward velocity to avoid the risk of scouring settled sludge is 10 to 15 mm/s (06 to 09m/min or 2 to 3 ft/ min), indicating that the ratio of length to width l/w should preferably be about.
- The maximum weir loading rate, to limit the influence of draw-down currents, is preferably about 300 m<sup>3</sup>/d-m, this figure is sometimes increased where the design flow is greater than 3 ADWF.
- Inlets should be baffled to dissipate the momentum of the incoming flow and to assist in establishing uniform forward flow.

- Sludge is removed by scraping it into collecting hoppers at the inlet end of the tank.
- Some removal is essential in primary sedimentation tanks because of the grease and other floating matter which is present in wastewater. The sludge scrapers can return along the length of the tank at the water surface. As they move towards the outlet end of the tank, the flights then move the sludge towards a skimmer located just upstream of the effluent weirs.

## **Circular Tanks**

These are also used for primary sedimentation.

- Most common-have diameters from 3 to 60m (side water depth range from 3 to 5m)
- Careful design of the inlet stilling well is needed to achieve a stable radial flow pattern without causing excessive turbulence in the vicinity of the central sludge hopper.
- The weir length around the perimeter of the tank is usually sufficient to give a satisfactory weir loading rate at maximum flow, but at low flows, very low flow depths may result.
- To overcome the sensitivity of these tanks to slight errors in weir level and wind effects, it is common to provide v-shaped weirs.
- Sludge removal is effected by means of a rotary sludge scraper which moves the sludge into a central hopper, from which it is withdrawn.
- Scum removal is carried out by surface skimming board attached to the sludge scraper mechanism and positioned so that scum is moved towards a collecting hopper at the surface.

## **Square tank**

- They may be flat bottomed or hopper bottomed. Wastewater enters the tanks, usually at the center, through a well or diffusion box.
- The tank is sized so that retention time is about 24 (range 20 minutes to 3h).
- In the quiescent period, the suspended particles settle to the bottom as sludge and are raked towards a central hopper from where the sludge is withdrawn.
- Primary sedimentation is among the oldest wastewater treatment process. Traditionally the design criteria for sizing settling tanks are:

**Average overflow rate:** 30 - 50 m<sup>3</sup>/m<sup>2</sup>/d

**Peak hourly overflow rate:** 50 - 120 m<sup>3</sup>/m<sup>2</sup>/d

**Weir loading rate:** 1.5 - 2.5h

- Always provide minimum of 2 sedimentation tanks.
- Sludge accumulation is same for both.
- Sludge accumulation 2.5kg of wet solids per m<sup>3</sup> of flow

## **Design Details of tank**

- Detention period for plain sedimentation 3- 4hours
- Velocity of flow not greater than 30cm/ min( horizontal flow).
- Tank dimensions: L:B = 3 :1to 5:1. Generally L= 30 m (common) maximum 100 m. Breadth= 6 m to 10 m.
- Depth 3.0 to 6.0 m
- Circular: Diameter not greater than 60 m. generally 20 to 40 m.

- Slopes: Rectangular 1% towards inlet and circular 8%.

## **Sedimentation with Coagulation**

### **Necessity of Sedimentation with Coagulation**

- Very fine suspended clay particles are not removed by plain sedimentation.
- Silt particle of 0.06 mm size requires 10 hours to settle in 3 m deep plain sedimentation tank and 0.02 mm particle will require about 4 days for settling.
- This settling time is impracticable, because water cannot be detained for such a long time. In plain sedimentation tanks detention time of about 2 hours for mechanically cleaned basins and about 6 hours for ordinary tanks, can be allowed.
- In addition to fine suspended matter, water also contains electrically charged colloidal matter which are continuously in motion and never settle down due to gravitational force.
- When water contains such fine clay particles and colloidal impurities, it becomes necessary to apply such process which can easily remove them from the water. After long experience it has been found that such impurities can be removed by sedimentation with coagulation.

### **Process of Sedimentation with Coagulation**

- It has been found that when certain chemicals are added to water an insoluble, gelatinous, flocculent precipitation is formed.

- This gelatinous precipitate during its formation and descent through the water absorb and entangle very fine suspended matter and colloidal impurities.
- The gelatinous precipitate therefore has the property of removing fine and colloidal particles quickly and completely than by plain sedimentation. T
- these coagulants further have the advantages of removing colour, odour and taste from the water.
- These coagulants if properly applied are harmless to the public.

### **Chemical used as Coagulants in Sedimentation with Coagulation:**

**The following are the most commonly used coagulants:**

#### **(a) Aluminium sulphate [ $\text{Al}_2(\text{SO}_4)_3 \cdot 18\text{H}_2\text{O}$ ]:**

- It is also called simply as alum. Alum which is available in market, is dirty grey solid in the form of lumps containing about 17% aluminium sulphate.
- This is the chemical coagulant which is widely used in water treatment plants.
- Alum reacts in water in the presence of alkalinity; if natural alkalinity is not present sufficient lime is added.
- The insoluble and colloidal aluminium hydroxide [ $\text{Al}(\text{OH})_3$ ] forms the floe which removes the fine suspended and colloidal impurities.
- For best results the pH value of water should be between 6.5 and 8.5. The dose of alum should be 0.03 to 0.13 gm/litre depending on the turbidity of water.

- The amount of alum required for coagulation mainly depends on the turbidity and colour of water.
- The quantity of optimum dose of alum is determined by practical test in the laboratory and it should be adopted in the practice also.
- Usually the dose of alum varies from 5 mg/litre for relatively clear water to about 25 mg/litre for very turbid waters.
- The average dose is about 19 mg/litre.
- Filter alum is very effective coagulant and is now-a-days extensively used throughout the world.
- It is cheap, forms very good stable floe, and also does not require skilled supervision or handling.
- The water obtained after its treatment is very clear.
- The main difficulty in using alum was to remove the water from the floe and its disposal.
- But now-a- days processes have been discovered to recover the alum from the sludge and reuse it in coagulation.
- The cost of recovery is also about 1/4th the cost of first cost of alum.
- The reuse of sludge has also removed the problem of sludge disposal.

**(b) Sodium Aluminate [ $\text{Na}_2\text{Al}_2\text{O}_3$ ]:**

This is an alkaline compound.

The best grade it contains  $\text{Al}_2\text{O}_3$ , 55%;  $\text{Na}_2\text{O}_3$ , 34%;  $\text{Na}_2\text{CO}_3$  4.5%;  $\text{Na (OH)}$ , 6.3%.

This can be used for treatment very easily in the water having no alkalinity.

It reacts very quickly and forms the precipitate of aluminium hydroxide.

$\text{CaAl}_2\text{O}_4$  is the required floe, which causes sedimentation.

Sodium aluminate does not increase the non-carbonate hardness and it can be easily mixed with lime and soda ash solution.

It has the further advantage of removing corrosive qualities of the water.

But it is costly due to which it is not widely employed in the water works practice.

### **(c) Ferric Coagulants:**

Generally ferric chloride ( $\text{FeCl}_3$ ), ferric sulphate [ $\text{Fe}_2(\text{SO}_4)_3$ ] or the mixture of both is used for coagulation purpose.

**The various chemical reactions which take place are as follows:**

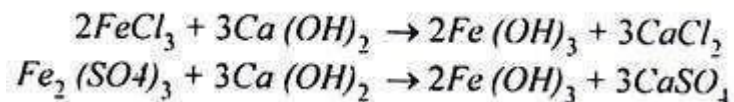

### **(d) Chlorinated Copperas:**

It is a mixture of ferric chloride and ferric sulphate prepared by adding chlorine to a solution of ferrous sulphate in the ratio of 1 part chlorine to 7.9 parts copperas.

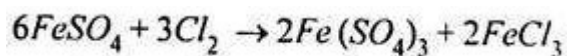

- It is very good coagulant and requires less amount of alkalinity in the water for floe formation.
- The produced floe is tough and easily settles due to which only small residue goes in the filters. This coagulant removes colours very well.

### **(e) Ferrous Sulphate and Lime:**

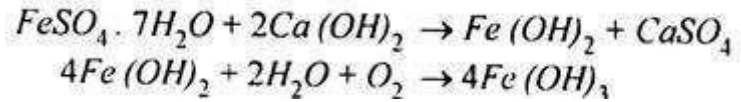

- $\text{Fe}(\text{OH})_3$  is the floc, which causes sedimentation.
- Ferric coagulants are good oxidising agents due to which these also remove hydrogen sulphate, tastes and odours from the water.
- These coagulants are generally used in the treatment of sewage.
- Ferrous sulphate as  $[\text{FeSO}_4 \cdot 7\text{H}_2\text{O}]$  is commonly used in coagulation.
- It is cheaper than alum, and gives good results above pH-value of 8.5.
- But for coloured raw water it is not used.
- The quantity of ferrous sulphate as required is more or less the same as that of alum.

### **Devices used during Sedimentation with Coagulation:**

#### **a. Feeding Devices:**

- Coagulants can be fed in dry or liquid form. Dry feed devices are desirable because they are simple, require small space for installation, keep neatness, are free from corrosion and are economical.
- But all the coagulants cannot be fed by dry feed devices, because some coagulants have characteristics of clogging, caking and deliquescence.
- The coagulants which have uniformity in grain size, constancy in composition, free from being hygroscopic or efflorescent and remain dry under various conditions of temperature and pressure are suitable for feeding in dry form. Aluminium sulphate can be fed in dry condition.

- The coagulants which are of corrosive nature and create difficulties in solution feed method should also be fed in dry form.
- The water of crystallization of ferrous sulphate changes with temperature therefore it is difficult to be fed in dry form because its powder may change to a solid mass, in the same way hydrated lime cannot be easily fed in dry form, because it may absorb moisture from air and become slaked lime.
- The choice of feeding device depends on the type of coagulant and the economy in total cost of plant. In large water works where large quantity of coagulants is required, the chemicals are purchased in the cheapest form and then feeding device is decided.
- In the case of small waterworks or where small quantity of water is to be treated the cost of feeding device is the main deciding factor. At such places cheapest type of feeding device is installed and the coagulants which suit it are used.

**b. Dry Feed Devices:**

- These devices are designed on volumetric or gravimetric displacement of dry-chemicals. The chemicals are kept in the hoppers.
- Required amount of coagulant is fed by revolving the helical screw or the toothed wheel fixed at the bottom of the conical hopper.
- Only required amount of coagulant is drawn off continuously.

- The speed of rotation of helical screw or toothed wheel is controlled by means of a venturi device installed in the raw water channels or pipes through which raw water flows to the treatment plant.
- When the quantity of raw water increases automatically the speed of rotation is increased and required amount of coagulant is fed in water at every time.

**c. Solution Feed Devices (Wet Feeding):**

- The chemicals whose solutions can be easily prepared are suitable to be fed by this method.
- First of all solution is prepared by placing the coagulants in a metal basket, perforated concrete box or perforated wooden box and then spraying warm water over it.
- The solution so prepared is kept in large tanks to hold sufficient quantity for one operation shift.
- Sometimes solution pot is used for this purpose which is most satisfactory method. In the pot coagulants are kept through which the water flows.
- The rate of flow in the solution pot is directly proportional to the flows in the main channel. Sufficient coagulants are kept in the pot to maintain a saturated solution in the effluent pipe.
- The solution is kept in a constant solution level tank, having a tapered hole in the bottom, which is controlled by a conical plug operated by a rod connected to the pulley.

- A small float chamber is constructed and connected to the raw water channel by means of a pipe.
- A float is kept in float chamber and it operates the pulley by means of a rack and pinion arrangement.
- . When the quantity of raw water increases, the water level in float chamber also increases and lifts and float.
- The lifting of float operates the pulley and the conical plug is also lifted thus increases and lifts the flot.
- The lifting of float operates the pulley and the conical plug is also lifted thus increasing the opening of tapered hole causing more solution to reach the raw water.
- The float and conical plugs are so interconnected by means of pulley, shaft, rack and pinion arrangement that only required amount of solution reaches the raw water channel in every case.
- Thus, this device is an automatic device for feeding solution of coagulants.

#### **d) Mixing Devices:**

- After adding coagulants in water, the next operation is to mix them thoroughly in water so that they fully disperse in the whole water.
- This mixing is done by mixing devices.
- In these devices first the coagulants are vigorously and rapidly mixed for about one minute.

- Then the mixture is gently agitated for about half an hour so that coagulants may react and start coagulation.
- The velocity of flow of water in mixing basins is kept between 15-30 cm/sec.
- The velocity in no case should be less than 10 cm/sec. and more than 75 cm/sec., because in first case the floc will settle down and in second case disintegrate.

**Mixing can be done by one of the following devices:**

**(i) Baffle Type Basins:**

- In these basins water may flow round about the end baffles or up and down past under and over baffles, the baffle walls are placed 60-100 cm apart and the velocity of water is kept between 15-30 cm/sec.
- . The detention period in these basins is kept 20-50 minutes.
- These are not suitable for small plants because these are costly in construction, have less flexibility of control, and greater loss of head.

**(ii) Flash Mixer:**

- In this device the solution of coagulants is mixed thoroughly in the water by means of a fan operated by electric motor suitable drive.
- The water enters in through the inlet, the deflecting wall deflects the water towards fan blades where chemicals also reach through chemical pipe.

- The rotating fan mixes coagulants with water which finally goes out from outlet.

### **(iii) Deflector Plate Mixer:**

- In this device the mixing is done by diffusing the water through a deflector plate.
- Water enters from inlet pipe, then it comes out from the holes provided below the deflector plate where it is agitated rapidly.
- Chemical pipe brings the coagulants near deflector plate, where they are thoroughly mixed with water.

### **Flocculation and Clarifiers used during Sedimentation with Coagulation:**

- After thoroughly mixing of coagulants in the water the next operation is flocculation. Flocculators are slow stirring mechanisms, which forms floe.
- Flocculators mostly consist of paddles which are revolving at very slow speed about 2-3 r.p.m. The paddles may revolve on a vertical or horizontal shaft.
- The flocculators provide number of gentle contacts between the flocculating particles which are necessary for the successful formation of floe. In one type there are number of compartments fitted with rotating paddles.
- The water enters from the inlet and leaves through outlet. The detention time for best results should be between 30-60 minutes.

### **Clarifiers:**

- In this operation the floe which has been formed above is allowed to settle and is separated from the water.

- This is done by keeping the water in sedimentation tanks which are also known as coagulation basins.
- The design of clarifiers is similar to that of plain sedimentation tanks. Some clarifiers are fitted with a moving arm known as raking arm.
- These devices are also fitted with continuous sludge removing arrangements.

## **Filtration**

Filtration is technically defined as the process of separating suspended solid matter from a liquid, by causing the latter to pass through the pores of a membrane, called a filter.

### **Filtration Process**

- The mixtures are of two main types: homogeneous mixtures and heterogeneous mixtures. A homogeneous mixture is a mixture that is uniform throughout.
- A heterogeneous mixture is a mixture that is not uniform throughout, i.e., ingredients of the mixture are distributed unequally.
- Air is a homogeneous mixture of different gases, including oxygen, nitrogen, carbon dioxide, and water vapour.
- Homogeneous mixtures are sometimes also called solutions; especially when it is a mixture of a solid dissolved in a liquid.
- Filtration also plays a role in water treatment.

- The process of filtration can become a costly process when it comes to water treatment and water purification.
- Maintenance and lack of regulation can become major disadvantages of filtration.
- Also, water treatment filters are not regulated by any health commission or department, so the effectiveness of filtration and purification can vary widely between manufacturers.
- But filters have enough advantages to be used as a mechanism of water treatment or purification.

### **Filter materials**

#### **➤ Sand**

- The filter sand should generally be obtained from rocks like quartzite and should contain following properties:

1. It should be free from dirt and other impurities
2. It should be uniform in nature and size
3. It should be hard and resistant

- The selection of the correct effective size is very important, because too smaller size will lead to clogging and too large will lead to escaping of suspended particles and bacteria.

## ➤ Gravel

- The gravel which may be used below the sand should be hard, durable, free from impurities, properly rounded and should have a density of about 1600 kg/m<sup>3</sup>.
- Gravel of different sizes are usually placed in 3 to 4 layers each of 15 to 20cm depth, with coarsest size – 20 to 60cm placed at bottom-most layer and finest size – 3 to 6cm as top most layer.

## **Theory of filtration**

“In order to remove or to reduce the contents of impurities still further, the water is filtered through the beds of fine granular material like sand”

The filters purify water under four different processes, as summarized below:

- Mechanical straining
- Flocculation and sedimentation
- Biological metabolism
- Electrolytic changes

## **Mechanical straining**

- The suspended particles present in water, and which are of bigger size than the size of voids in the sand layers of the filter, cannot pass through these voids and get arrested in them.
- Therefore, the resultant water will be free from these impurities.

## **Flocculation and sedimentation**

- The filters whose voids size is more than the size of particles, also able to remove such particles. This fact is possible by assuming the voids spaces acting as tiny coagulation-sedimentation tanks.
- The colloidal matter arrested in these voids is a gelatinous mass and , therefore, attract other finer particles. These finer particles settle down in the voids and get removed.

## **Biological metabolism**

- Generally micro-organisms and bacteria are reside in voids as coatings over sand grains during the initial process of filtration. And, these organisms use organic impurities as their food and convert them into harmless compounds.
- Such harmless compounds form a layer on the top, which is called dirty skin.

## **Electrolytic changes**

- The purifying action of filter can also be explained by the theory of ionisation.
- This may be explained by that, the sand grains of filter media and the impurities in water, carry electrical charges of opposite nature.
- When these oppositely charged particles and the impurities come in contact with each other, they neutralise each other, there by changing the character of water and making it purer.

- After a certain interval, the electrical charges of sand grains get exhausted, and have to be restored by cleaning the filter.

### Types of filters

- The various types of filters are commonly used for treating municipal water supplies are:

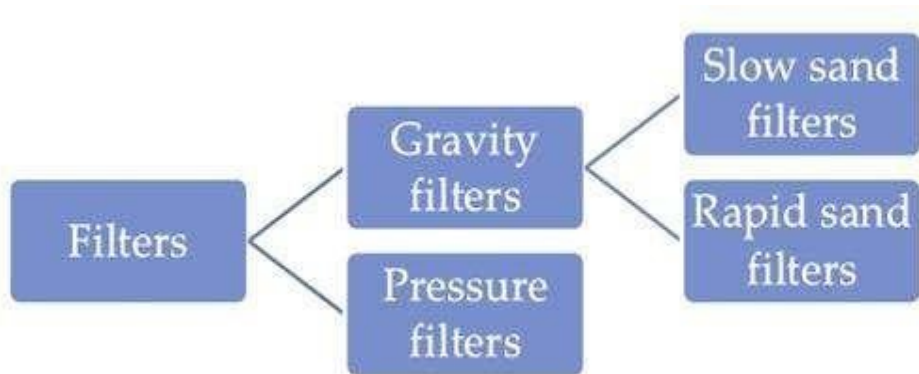

### Slow sand filters

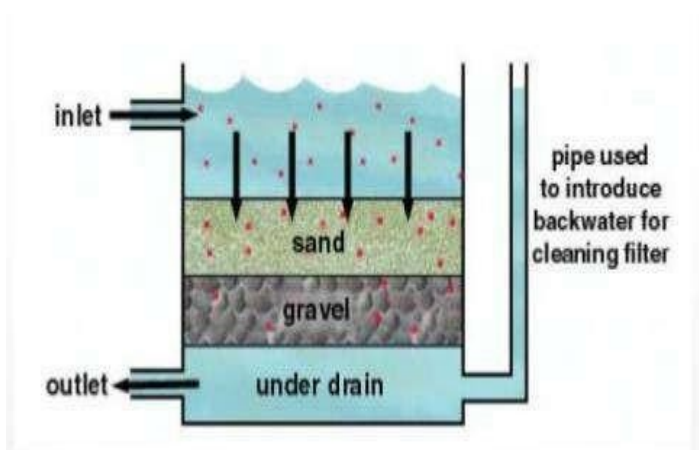

➤ **Purpose**

The water is allowed to pass slowly through a layer of sand placed above the base material and thus the purification process aims at simultaneously improving the biological, chemical, and physical characteristics of water.

➤ **Essential parts**

**Enclosure tank:**

- An open water tight rectangular tank, made of masonry or concrete
- It is a waterproof material
- The bed slope is 1 in 100 to 1 in 200
- The depth of the tank is 2.5 m to 3.5 m

**Under drainage system:**

- The under drainage system consists of a central drain and lateral drains.

**Lateral drain:**

- It is placed at a distance of about 2.5 to 3.5 m
- Stopped at a distance of 500 mm to 800 mm from walls of the tank.
- Open joint pipes

**Base material:**

- Placed on top of the underdrainage system
- Varies from 300 mm to 700 mm depth
- Graded and laid in layers of 150 mm

- The size of gravel in each layer should be as :

bottom most layer – 40-65 mm

Intermediate layers – 20-40mm & 6-20mm

Top most layer – 3-6mm

### **Filter media:**

- Sand layer is placed above the gravel of layer depth 600 mm to 900 mm.
- Size of the sand varies from 0.2 mm to 0.3 mm.
- Uniformity coefficient of sand is 2 to 3.
- The finer the sand, the better will be the filtration.

### **Working:**

- The water is allowed to enter the filter through the inlet chamber. It descends through the filter media and during this process, it gets purified
- These filters are usually worked for a maximum filtration head of 750 mm.

### **Cleaning:**

- Top layer of the sand is removed to a depth of 15 to 25 mm
- Effective depth of filter media is reduced
- Fresh layer of 150mm depth of graded sand is added

## Rate of filtration:

100 to 200 litres per hour per m<sup>2</sup> of filter area

## Efficiency:

- Bacterial load-99.50 to 99.9 percent is removed
- Colour: less efficient in removal of colour(20-25%)
- Turbidity: can remove turbidity of 50 p.p.m

## Rapid sand filters

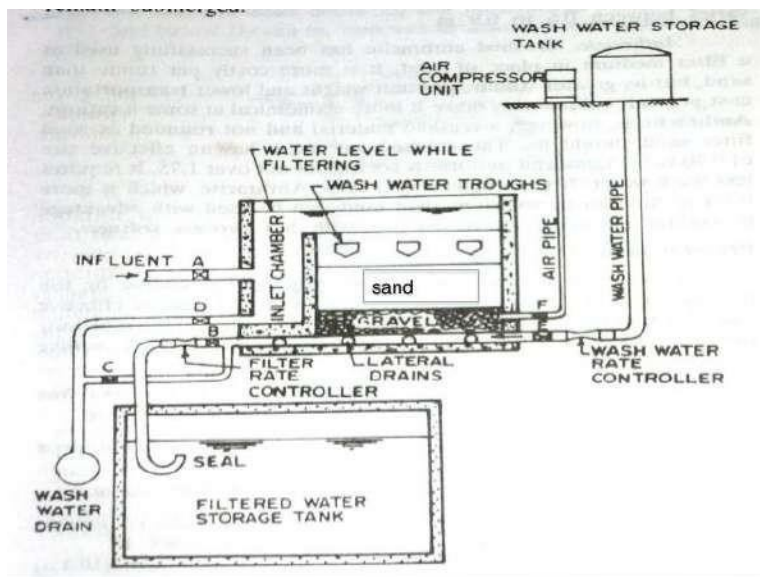

### ➤ Purpose

Rapid filters are used primarily to remove turbidity after coagulation and flocculation in large water treatment plants.

### ➤ Essential parts

**Enclosure tank:-**

- It is Smaller in size, therefore can be placed under roof.
- Rectangular in shape and constructed of concrete or masonry.
- Depth – 2.5 to 3.5 m
- Surface area – 20 to 50 m<sup>2</sup>.

**Filter media:-**

- Should be free from dirt, organic matter and
- It should be hard and resistant.
- Depth of sand media – 0.6 to 0.9 m
- Effective size – 0.35 to 0.6 mm (Common value 0.45)
- Uniformity coefficient – 1.2 to 1.7 (Common value -1.5)

**Estimation of sand depth :-**

- The depth of sand bed should be such that flocs should not break through the sand bed.
- Depth varies from 60 to 90 cm.

**Base material :-**

- Depth 45 to 60 cm
- The size of gravel in each layer should be as:-

topmost - 3 to 6 mm , Intermediate -6 to 12 mm & Bottom - 20 to 50mm

### **Under drainage system**

To collect filtered water uniformly over the area of gravel bed

#### **Working**

- All valves are kept closed except valves A and B. •Valve A is opened to permit water from clarifier
- Valve B is opened to carry filtered water to clear water sump
- Head of 2m over sand bed is maintained
- Designed filtration rate are 3000 to 6000 lit/m<sup>2</sup>/hr
- Filter run depends on quality of feed water
- Filter run may range between less than a day to several days
- Objective of backwash is to remove accumulated particles on the surface and within the filter medium
- Backwash is performed using wash water or air scouring.

#### **Back washing**

- Filter is back washed when head loss through it has reached the maximum permissible.
- RSF are washed by sending air and water upwards through the bed by reverse flow through the collector system.

- 2% - 4% filtered water is used for backwashing

### **Pressure filters**

Filter is enclosed in space and the water passes under pressure greater than atmospheric pressure”

#### **Construction:**

- It is Closed steel cylinders.
- Diameter varies from 1.5 to 3.0 m.
- Length or height varies from 3.5 to 8.0m.
- Manholes are provided at the top for inspection.

#### **Working**

- The water mixed with coagulant is directly admitted to the pressure filter.
- In working condition all valves are closed except those for raw water and filtered water.

#### **Cleaning**

- The compressed air may be used to agitate sand grains.
- Valves for wash water and wash water drain are opened during washing.

**Rate of filtration:** 6000-15000litres/hr/sq.m.

**Efficiency:** Less efficient than the rapid sand filters.

## **Disinfection of Water**

- The chemical used for killing these bacteria are known as disinfectants and the process is known as **disinfection**
- The purpose of disinfecting drinking water is to destroy organisms that cause diseases in human beings & these bacteria must be killed to make the water safe for drinking
- Most pathogenic bacteria are removed from water in varying degrees during the different treatment processes (coagulation, sedimentation, and filtration).
- Disinfection is used to ensure satisfactory removal of pathogens from potable water.
- The presence of turbidity's, colour, minerals etc may not be dangerous but the presence of even single harmful organism will be definitely dangerous thereby making disinfection as the most important process.
- The disinfection not only removes the existing bacteria from the water at the plant but also ensures their immediate killing even afterwards in the distribution system.

## **Necessicity of disinfectant**

1. Disinfectant shall be effective in killing the microorganisms.
2. Should be cheap and readily available.
3. Should be safe to handle and easy to apply.
4. It should not make water toxic in nature.
5. It should have ability to persist in residual state.

## **Methods of disinfection**

### ➤ **Boiling of water**

- Water shall be boiled at least for 15 to 20mins
- It is Most effective
- It can kill bacteria and viruses
- It cannot be used on large scale
- During epidemics it is used in domestic scale.

### ➤ **Ultraviolet rays**

- Ultraviolet rays are invisible rays having wavelength 1000- 4000 m $\mu$
- And can be produced by passing electric current through mercury enclosed in quartz bulbs.
- The water to be treated with ultraviolet rays should, however, be less turbid and low in colour.
- Normally it should be colourless and turbidity should not exceed 15 mg/l
- The depth of water over the bulbs should not generally exceed 10cm or so because these rays can effectively penetrate through this much distance only.

### ➤ **Iodine and Bromine**

- The quantity of this disinfectants may be limited to about 8 ppm and contact period of 5 minutes is generally enough.

- They are not used for treating any large scale public supplies but may be used for treating small water supplies for army troops, private plants, swimming pools etc.

➤ **Ozonation**

General characteristics of ozone are:-

- Powerful oxidant
- Unstable in aqueous solutions
- Has a half of 20 to 30 minutes in distilled water
- Widely used in drinking water treatment
- Is produced on -site and can not be stored site

➤ **High pH Treatment (Excess Lime)**

- Addition of excess lime kills bacteria in it
- Addition of 14-43 ppm of excess lime has been found to remove the bacterial load by about 99.3-100% from highly polluted waters.
- Bacteria gets killed due to increased pH value
- In this case, no residual will remain after neutralization

➤ **Potassium Permanganate**

- It is commonly used in rural areas.
  - Used for purification of open well water supplies.
  - $\text{KMnO}_4$  is dissolved in bucket and added in well water.
  - Water should not be used during first 48 hours after  $\text{KMnO}_4$  addition

- This is used as popular disinfectant for disinfecting well water in villages which are generally contaminated with lesser amount of bacteria.

### ➤ **Silver Treatment**

- Silver when immersed in water has inhibiting effect on bacterial life.
- As silver is costly this method can be used in small scale.

### **Softening Of water**

- Softening is reduction or removal of hardness.
- Hardness is due to divalent metallic ions like –  $Ca^{+2}$  ,  $Mg^{+2}$  ,  $Fe^{+2}$  ,  $Mn^{+2}$  ,  $Zn^{+2}$  etc.
- Two types of hardness.
  - i. Temporary or carbonate hardness
  - ii. Permanent or non-carbonate hardness
- Permissible hardness: 75 – 115 mg/l
- Softening may be done by the water utility at the treatment plant or by the consumer at the point of use

### **Removal of temporary hardness**

- Temporary hardness is due to carbonates and bicarbonates of calcium and magnesium.
- It can be removed either by boiling or by adding lime to the water.

### ➤ **Boiling**

- $CaCO_3$  is slightly soluble in water.
- So it usually exists in water as a bicarbonate.
- Boiling will lead to the precipitation of  $CaCO_3$  and release of  $CO_2$ .

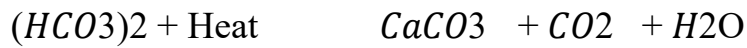

□  $CaCO_3$  is precipitated.

- Magnesium carbonates and bicarbonates are not satisfactorily removed.
- $MgCO_3$  is fairly soluble.

### ➤ Addition of lime

- Hydrated lime is added to the water.
- Efficient in removal of both calcium and magnesium carbonates.



- The precipitated compounds can be removed in the sedimentation tank.

### Removal of permanent hardness

The 2 methods are :-

- Lime-soda process

ii. Ion exchange process

**iii. Lime soda process**

- Both the carbonate and non carbonate hardness can be removed.
- Lime also helps in removal of free dissolved  $CO_2$ .

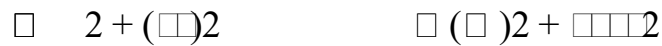
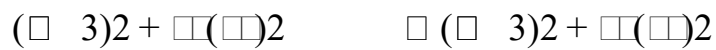

- Large quantity of sludges are encountered.

➤ **Ion exchange to remove hardness**

- Cation exchange

• Calcium and Magnesium can be replaced by a nonhardness cation usually Sodium.

- Synthetic resin(polymer) coated with exchange material in the modern applications.



- $Na_2(HCO_3)_2$  don't cause hardness.

- Home-use softeners are almost ion-exchange units.

- They may be either gravity or pressure filters.

## **CHAPTER 4**

### **Distribution system And Appurtenance in distribution system**

#### **Introduction**

- The purpose of distribution system is to deliver water to consumer with appropriate quality, quantity & pressure.
- Distribution system is used to describe collectively the facilities used to supply water from its source to the point of usage.

#### **Requirements of Good Distribution System**

- It should convey the treated water up to the consumers with the same degree of purity.
- The water should reach to every consumers with the required pressure head.
- It should be able to transport sufficient quantity of water during emergency such as fire fighting.
- It should be reliable so that even during breakdown or repairs of one line water should reach that locality from other line.
- It should be fairly water tight as to keep losses due to leakage to the minimum.

#### **Methods of water distribution**

- For efficient distribution system adequate water pressure required at various points.

- Depending upon the level of source, topography of the area and other local conditions, the water may be forced into distribution system by following ways –

I. Gravity System

II. Pumping System

III. Combined gravity and pumping system

1. Gravity system

- In this system the gravity force is used in distribution water from high level source to low level zone consumers.
- This eliminates pumping altogether. The method is economical reliable and required less maintenance. For proper working of the system the difference of head available between
- Service reservoir and low level zone should be sufficient to develop enough pressure at consumers tap. The method also minimises wastage and leakages.

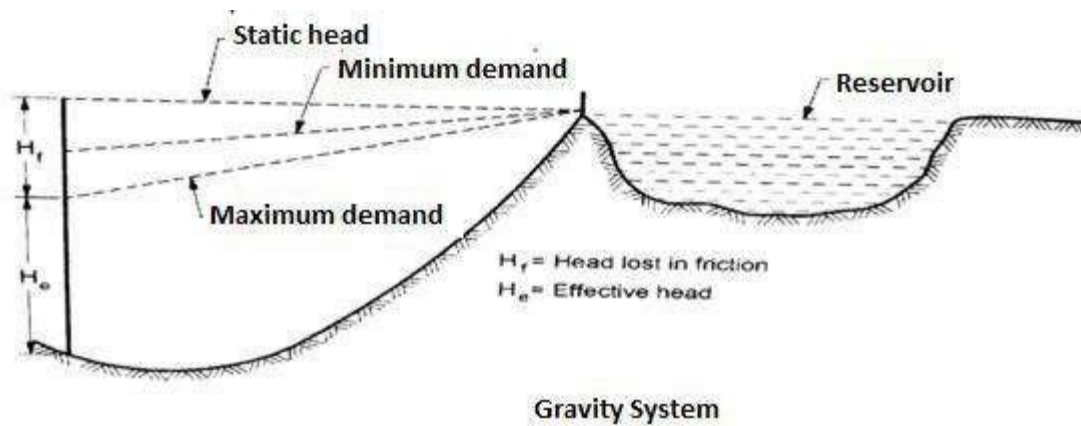

## **Advantages**

- A. Simple and economical.
- B. Less maintenance.
- C. Less leakage and wastage.
- D. Reduction in pipe sizes.

## **Disadvantages**

- A. Not suitable if source is not a sufficient elevation to cause flow under gravity.
- B. Cannot provide high pressure for fire demand.

## **2. Pumping system**

- The treated water is directly pumped into distribution mains without storing in high level reservoirs. High lift pump are provided for forcing water into mains.
- Since the water is fluctuating the pumps have to operate at various rate during the whole day. A continuous attendance is required at the pumping station to regulate the flow by running only the required number of pump out of total number of pump install.
- During failure of pump and electric supply the water supply to the town may be interrupted to avoid this it is desirable to have some units of pump running on diesel.
- Pumping system can supply the required quantity of water for firefighting by running all pumps including standby. The system is costly and its use should be discourage as far as possible.

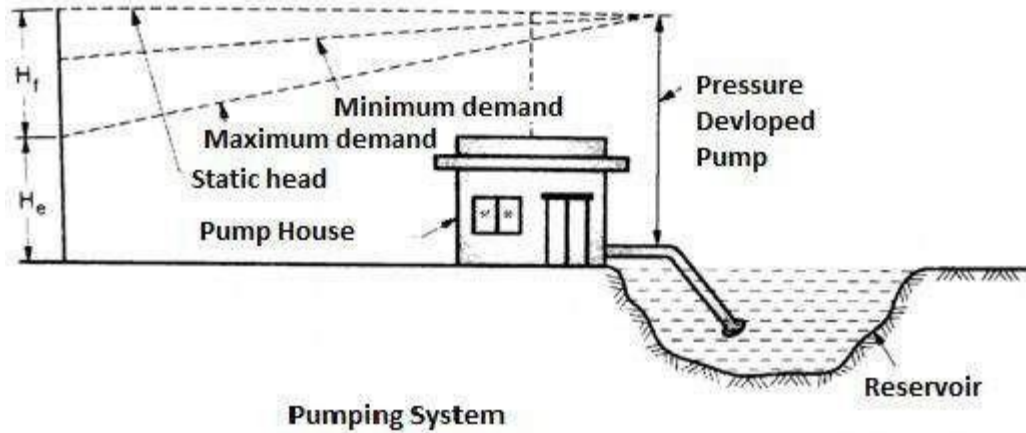

### Advantages

- A. Large quantity of water available in case of fire.
- B. Suitable for any type of topography.

### Disadvantages

- A. Sufficient water required.
- B. Not economical.
- C. More losses and wastage.

### Combine of gravity and pumping system

- In this system the water after treatment is pumped and stored in the elevated services reservoir (ESR) according to the supply hours the store water supply to the public by gravity.

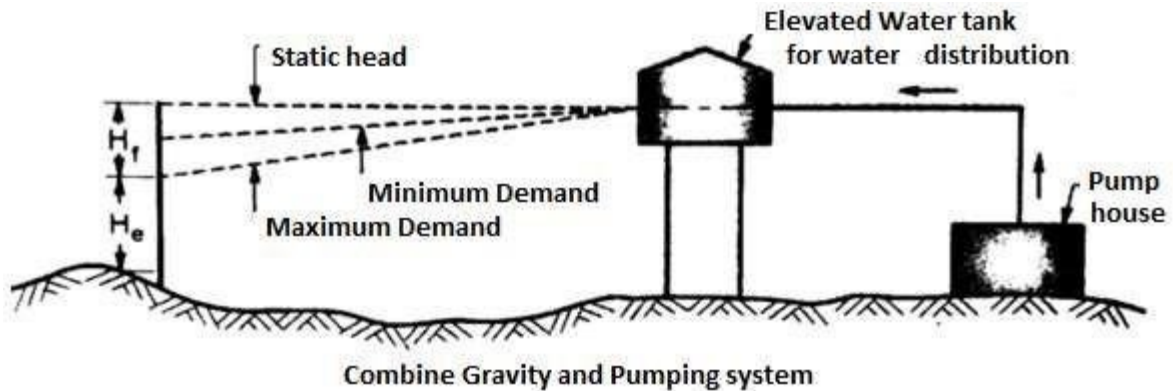

### Advantages

- A. The system is economical, efficient and reliable and adopted practically everywhere.
- B. Pumping at constant rate increases efficiency.
- C. Special supervision is not required.
- D. Fire demand efficiently met with.
- E. Water is available even during failure of pump and power.

### Layout of distribution pipe network

Distribution pipe are always laid below the roads prevailing in the town. Also they are laid on one side of the road, keeping the other side of the road for laying of sewer in future. The layout of pipelines naturally fallows the pattern of road.

Following are the four type of system.

1. Tree end system
2. Ring or circular system
3. Grid or interlaced system
4. Radial system.

## 1. Tree end system (dead end system)

In this system there is one main pipe line is laid along main road and submain branches minor distributary are laid along the other road and streets connecting main road.

This system is also known as dead end system.

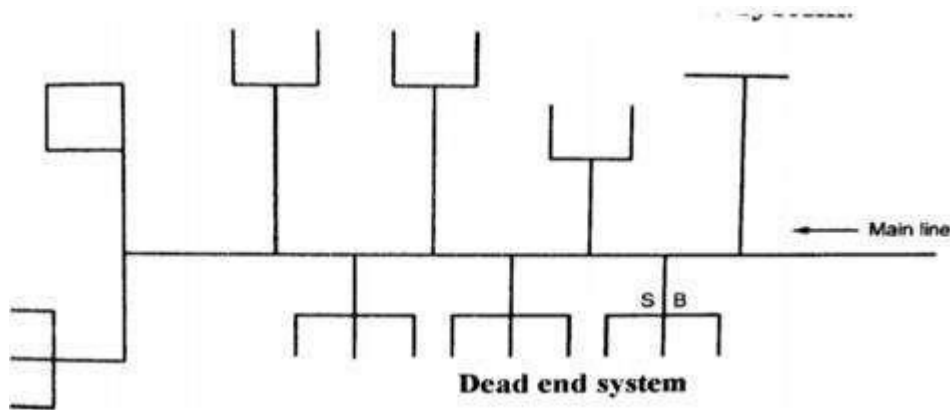

Tree system is used in town or cities which are not well planner.

### Advantages

- A. Cheap in initial cost
- B. Easy determination of pipe size
- C. Laying of pipe simple
- D. Less number of valve are required.

### Disadvantages

- A. This system cannot meet fire demand
- B. Due to stagnation water get polluted.

### Ring or circular system

In this system the area is divided into blocks.

Water mains are laid around the blocks from all side.

The branches submain are taken along inner road and interconnected.

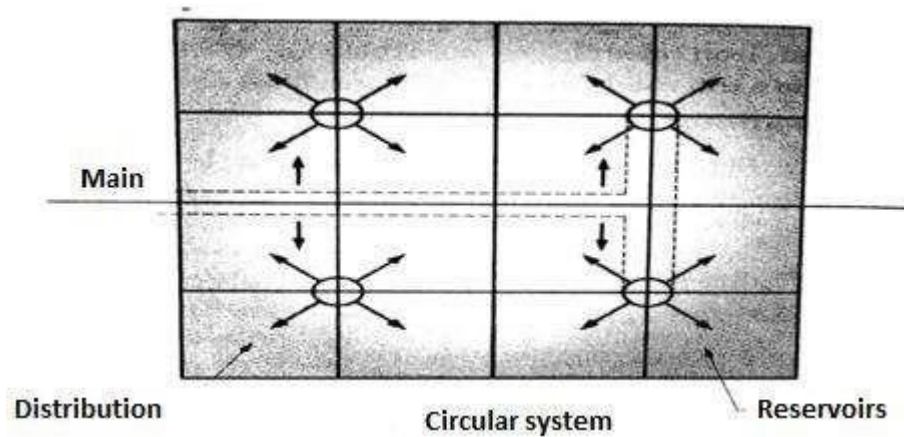

This system is suitable for well-planned cities.

### **Advantages**

- A. Water is available for fire demand.
- B. Designation of pipe is simple and easy.

### **Disadvantages**

- A. The system is costly to construct.
- B. It is required more length of pipe and more number of slice valves.

### **Grid or interlaced system**

A main pipe is laid along main road and submain branches are laid along inner road and interconnected so that water remain in circular and there are no dead end.

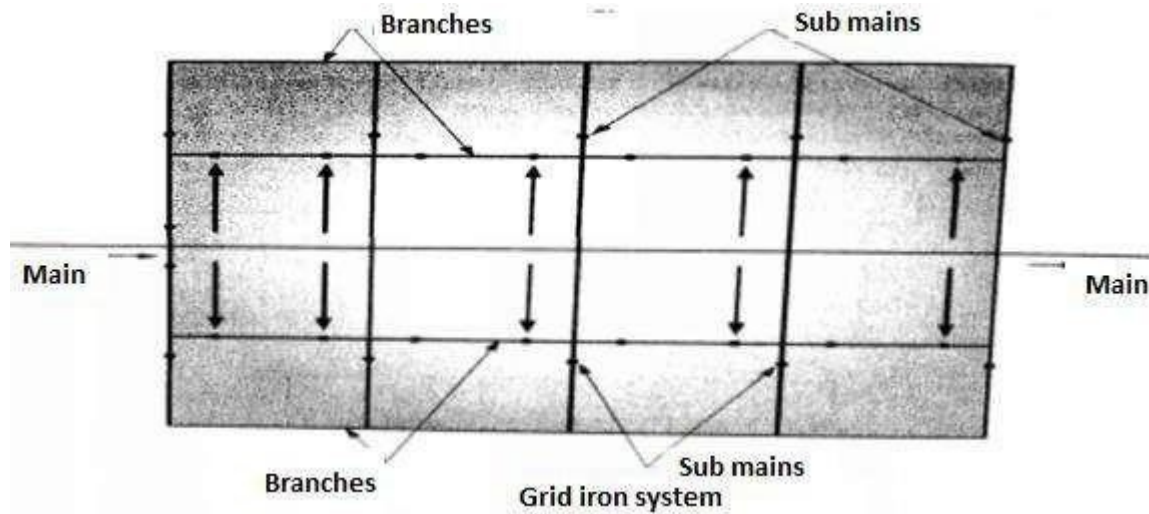

grid iron system is suitable for well-planned cities. Where the roads are at right angle to each other.

#### *Advantages*

- A. There are no dead ends so water is not stagnated.
- B. Size of pipe is reduced.

#### *Disadvantages*

- A. More number of valves is required.
- B. Costly
- C. Longer length of pipe required.

#### **Radial system**

The system consist of laying pipeline radially end of the periphery of the area of the zone.

In end zone elevated service reservoir is placed at it centre from where water is admitted to this radially laid pipe known as branches.

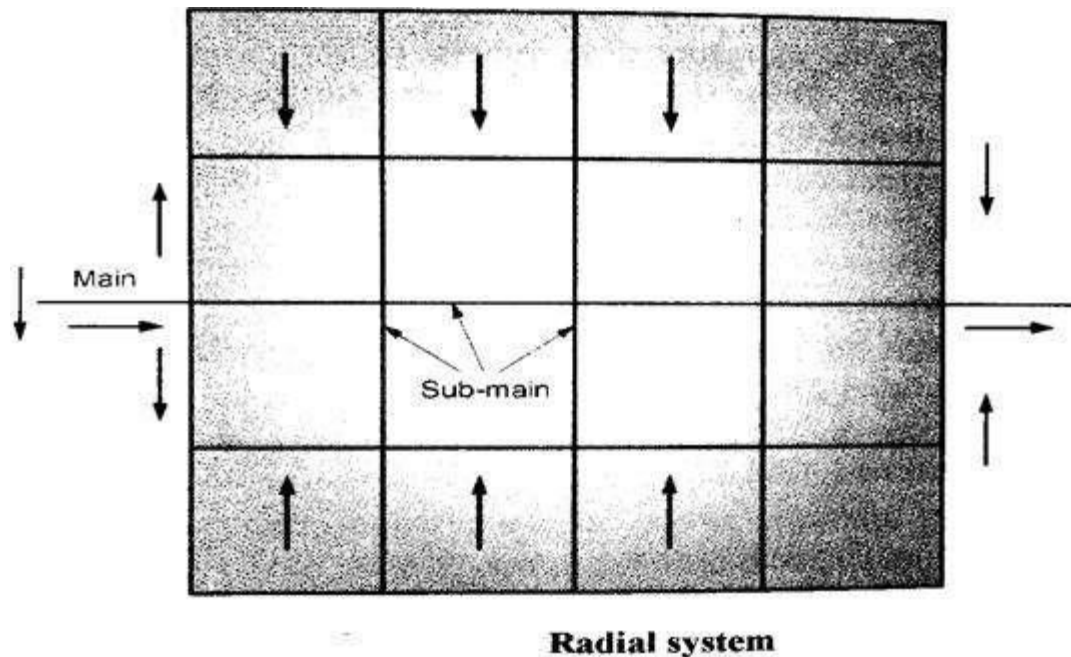

This system is suitable for localities having radial pattern of road.

### **Advantages**

- A. Designation of pipe size is simple
- B. There is quick and efficient supply of water.

### **Disadvantages**

- A. As every zone required a separate service reservoir number of reservoir required more and hence the systems become costly.

### **Methods of supplying water**

The water may be supplied to the consumers by either of the two systems.

#### **1. Continuous system**

- This is the best system and water is supplied for all 24 hours.

- In this system sample of water is always available for fire fighting and due to continuous circulation water always remains fresh.
- In this system less diameter of pipes are required and rusting of pipes will be less.
- Losses will be more if there are leakages in the system.

## **2. Intermittent system**

- If plenty of water is not available, the supply of water is divided into zones and each zone is supplied with water for fixed hours in a day or on alternate days.
- As the water is supplied after intervals, it is called intermittent system.

## **Water supply appurtenances**

- The different devices required for controlling the flow of water, for preventing leakage and other purposes in water supply system are called “**appurtenances**”.
- The distribution pipes are provided with various pipe appurtenances or accessories so as to make the distribution of water easy and effective.

## **Necessity of water supply appurtenances**

- The main purpose of water supply appurtenances is to make the distribution of water easy and effective.
- To avoid wastage and leakage of water.
- To change the direction of flow of water in pipe line.

- To make the efficient use of water.
- To control the flow of water in opposite direction in pipe.
- To regulate the flow of water.

### **Requirements of water supply appurtenances**

- It should be strong, durable & economical.
- It should have resistance to corrosion.
- It should have resistance to internal pressure of water.
- It should be easy to remove & repair.
- It should not be affected by chemicals, acids.

**Some of the appurtenances which are commonly used in a distribution system are as follows:**

#### Valves

A valve is a device that regulates, directs or controls the flow of a fluid by opening, closing, or partially obstructing various passageways.

## **CHAPTER 5**

### **Water system plumbing in building**

#### **WATER SUPPLY DISTRIBUTION METHOD**

- After the cleaning process, water supply system will go through the main pipeline system that consists of several major pipelines .
- The main pipeline system connects the storage pool or the pumping station to the communication pipe that will supply water to the building.
- The piping system varies from one area to another depending on the size and characteristics of the area. Among the factors that affect the main piping system are:-
  - a) Physical conditions of soil
  - b) The number and types of users
  - c) The ability of water supply during peak demand.
  - d) Water loss in terms of friction

#### **Distribution System For Building (Building Distribution System)**

- At this level, water is conveyed from the street mains to the individual building, and then to the taps and other fixtures.
- The supply from the main line to the individual is made through the house service connection.
- The house service connection consists of two types:-

1. Communication pipe: The pipe which runs from the street mains/ municipal distribution/service mains to the boundary of the premises.
2. Supply pipe: The pipe which runs inside the premises is called as supply pipe/consumer's pipe.

## THE WATER CONNECTIONS

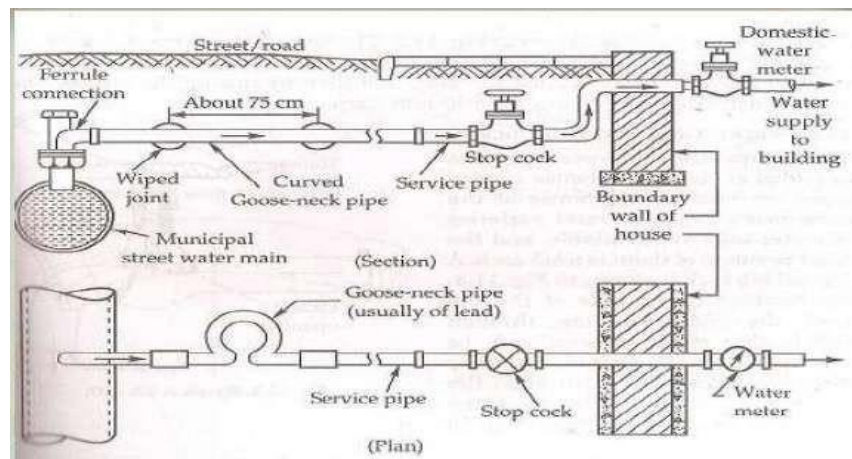

### House Water Connection

- i. Ferrule
- ii. Goose neck
- iii. Service pipe
- iv. Stop cock
- v. Water meter

#### 1. Ferrule

- Right angled sleeve made of brass and gun metal



- Size: 10 to 50 mm dia

## 2. **Goose neck**

- Small curved pipe made of flexible material
- Length : about 75mm
- Forms flexible connection between the water main and the service pipe

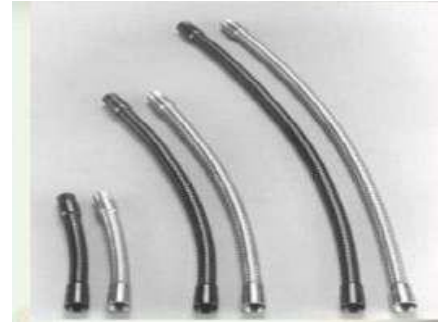

## 3. **Service pipe**

- Galvanized iron pipe of size less than 50mm dia
- Laid underground
- Connected to main through ferrule and goose neck



## 4. **Stop cock**

- Screw down type valve used for stopping and opening water supply
- Generally provided before the water enters the water meter
- Also provided inside the building

## 5. **Water meter**

- Measures and records the quantity of water consumed



- Generally fixed in an iron box fitted in an opening or cavity and covered with movable iron cover

- There are 2 types :

- a. Velocity meters
- b. Positive meters

### **Distribution System**

- For plumbing purposes, the term “multi-storey” is applied to buildings that are too tall to be supplied throughout by the normal pressure in the public water mains.
- Water main supply pressures of 8–12 meters (25– 40 feet) can supply a typical two-storey building, but higher buildings may need pressure booster systems.
- In hilly areas, the drinking-water supply pressures will vary depending on the ground elevation.
- In these cases, the water authority may have to specify areas where particular supply pressures can be relied upon for the design and operation of buildings.
- Where a building of three or more storeys is proposed a certificate should be obtained from the drinking-water supply authority guaranteeing that the present and future public drinking- water supply pressure will be adequate to serve the building.

### **Water Supply Systems**

There are 2 water systems :-

- a) Cold water Systems
- b) Hot water Systems

### **Cold water systems**

- **DIRECT**

UPFEED- Water is provided by the city water companies using normal pressure from public water main.

- **INDIRECT**

a) DOWNFEED or GRAVITY SYSTEM- Water is pumped into a large tank on top of the building and is distributed to the fixtures by means of gravity.

b) HYDRO PNEUMATIC SYSTEM/ AIR PRESSURE SYSTEM- When pressure supplied by city water supply is not strong enough then the Compressed air is used to raise and push water into the system

### **Hot Water Systems**

#### ***a) Range Boiler***

- Small hot water tank (30-60 cmL diameter; 180cm max length)
- Made of galvanized steel sheet, copper or stainless steel
- Standard working pressure limit is 85 to 150 psi

#### ***b) Storage Boiler***

- Large hot water tank (60-130 cm in diameter; 5m max length)
- Made of heavy duty material sheets applied with rust proof paint

- Standard working pressure limit is 65 to 100 psi.

## PLUMBING

- It is the art and technique of installing pipes, fixtures & other apparatuses in buildings & for bringing the supply, liquids, substances or ingredients & removing them.

Plumbing System –

- Plumbing System includes all potable water supply and distribution pipes, all plumbing fixtures and traps, all sanitary and storm drainage systems; vent pipes, roof drains, and all building drains and sewers, including their respective joints and connections; devices, receptacles, and appurtenances within the property; water lines in the premises

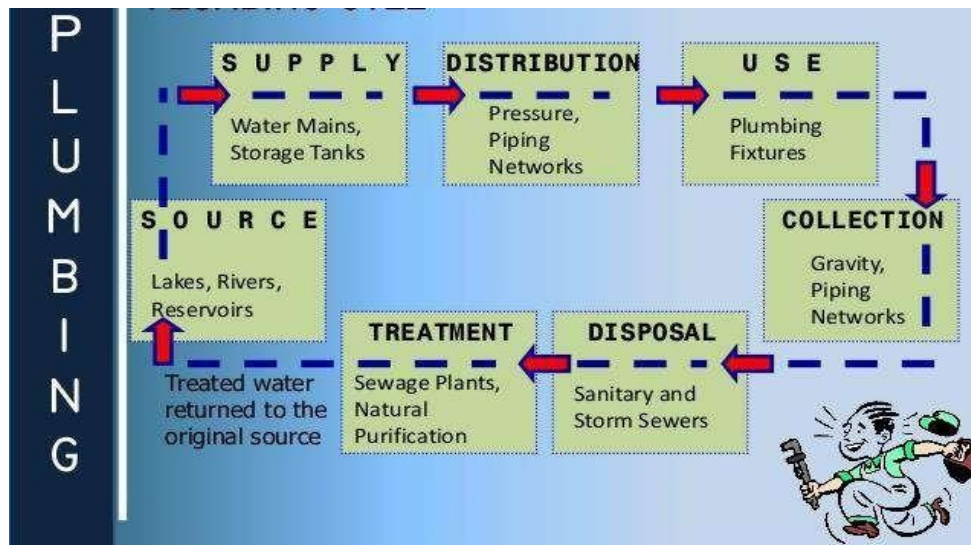

The plumbing and sanitary system is an essential part of every house or building. Proper planning and designing of plumbing system is crucial as it takes care of the hygiene requirements of the occupants.

It has been reported that about 8 per cent of the construction cost of a building is marked for plumbing and sanitary work.

A plumber's job role consists of installation, repair, maintenance and servicing of plumbing fittings and fixtures. Besides having a thorough understanding of the mechanisms required for performing various tasks, a plumber should be laborious, have effective communication skills and be a result-oriented worker with a positive attitude.

### **Role of Plumbing**

As you may be aware, water is supplied to a house or a building from storage tanks through pipes. Similarly, the waste water from kitchen and washrooms is drained out with the help of pipes.

Any building, be it a residential, commercial or industrial, cannot function properly without having plumbing and sanitary arrangements in place. It is, therefore, important to have regular and adequate water supply and a proper system for the disposal of waste water.

Plumbing cycle refers to a mechanism through which water is taken from a source, then supplied to the users, and finally waste water is collected and recycled to the source after proper treatment.

Plumbing and pipe-fittings play a major role in the construction of all types of buildings. An efficient plumbing work keeps the atmosphere free from bad smell and ensures better sanitation.

## **Sanitary Work**

Sanitary work refers to carrying the waste water to the waste disposal system (sewerage system) through plumbing fixtures.

The plumbing installation is governed by the regulations and rules adopted by the concerned municipal corporations or committees of different States and Union Territories. Plumbing and sanitation work thus plays an important role in the construction of a building.

A plumbing system consists of pipe fittings and appliances used for water supply and drainage, as you see the fitting for the washbasin .

In this system, different pipes are used for different purposes.

The plumbing system includes:

- water supply, galvanized iron (or plastic) pipes and fixtures;
- soil pipes and fixtures;
- sanitary drainage system; and
- rainwater drainage system.

For an efficient plumbing system, it is important that standard plumbing and sanitary material, as per the Bureau of Indian Standards (BIS), are used. It is also important that quality workmanship, practical checks and supervision are ensured during plumbing and sanitary work. It helps in getting the best out of the skilled and unskilled labour.

Before starting the work, the plumber must keep the following points into consideration.

1. Water supply system: sources of clean and potable water
2. Plumbing fixtures and pipes: knowledge about different requirements and specifications
3. Sanitary and drainage system: knowledge about sewerage system
4. Rainwater drainage system
5. Plumbing drawing and their uses: role of plumbing drawing

## CHAPTER-6

### INTRODUCTION OF SANITARY ENGINEERING

#### **Definition of Sanitary engineering or public health engineering or wastewater engineering**

- It is the branch of public health engineering which deals with the prevention and maintenance of the health of individual and the community.
- It consists of scientific and methodical collection conveyance, treatment and disposal of the waste water . Sanitary engg. includes these four categories :
  1. Water treatment systems
  2. Water distribution network
  3. Waste water collection system
  4. Waste water treatment systems

#### **Aims and objectives of sanitary engineering :-**

The objective of sanitary engineering is to improve sanitation of human communities, primarily by providing the removal and disposal of human waste, and in addition to the supply of safe potable water.

#### **Definition of terms related to sanitary engineering :**

##### **1. Refuse:-**

- It indicates what is waste or rejected .
- It may be in the form of liquid or solid .

It is divided into 5 category:-

a)Garbage

- b) Sewage
- c) Storm water
- d) Sub soil water
- e) Sullage

**a. Garbage:-**

- ❖ It is the solid waste produced at market places, public places etc.
- ❖ This type of waste is generally dry in nature .
- ❖ This include vegetable waste , decayed fruit,grass,leaves,plastics ,paper etc.

**b. Sewage :**

- This term is used to indicate the liquid waste from the community and it includes sullage, discharge from latrines, urinals, industrial waste and storm water etc.
- The sewage or night soil is collected from septic tanks of individual houses by the help of sewage tankers and then these are transported to the treatment plant or disposal site.
- The disposal site for sewage disposal must be for city or town area.
- The sewage can be dried in the disposal site to form compost.

**Types of sewage:**

Different sewage are :

- i) Combined sewage : This indicates a combination of sanitary sewage and storm water without industrial waste.

- ii) Crude or Raw sewage : This indicates the sewage that is not treated.
- iii) Dilute or weak sewage : This indicates the sewage containing less suspended solid.
- iv) Domestic or sanitary sewage This indicates the sewage mainly derived from residential or business meeting.

Sewage are also of following types : –

1. sanitary sewage :- waste water discharge from latrins and bathrooms
2. Industrial wastage :- waste water from industries
3. septic sewage :- This indicates the sewage which is undergoing the treatment process.
4. Night soil :- This indicates the human and animal excreta..
5. Fresh sewage :- The sewage which is recently produced.
6. Waste water :- The combined liquid and water carried wastes from residences,commercial buildings is known as waste water. It is same as sewage.
7. Dry weather sewage :- This indicates the flow of sewage during the dry season of the year.
8. Wet weather sewage :- This indicates the flow of sewage during the rainy season of the year.

### **C) Storm water:**

- This indicates the rain water of the locality.
- If heavy rainfall occurs in the city areas, the excess rain water is collected by open drains and is discharged off to river sites .

**D) Sub soil water**; It indicates the water which has accumulated in the stratum of earth immediately below the surface soil.

**E) Sullage** : It indicates the waste water from kitchen, bathroom ,etc .

## 2. Sewers :

The under ground drain lines,conduits,manholes etc. which carry the sewage are called sewer.

## 3. Sewerage :

- The entire science of collecting and carrying sewage by water carriage system through sewer is known as sewerage.
- The sewage thus collected and conveyed is taken to a suitable place to disposal.

## 4. Sewerage Network :-

- ❖ Sewerage Network is the connection of sewer lines , manholes, IC chamber etc. to collect the sewage from individual houses and transfer it to the treatment plant or disposal point .
- ❖ Sewage is otherwise called “Night soil.”

## Method of carrying of waste water or refuse :-

The following are the two methods which are employed for the collection and disposal of refuse of a locality :-

1. Conservancy system
2. Water Carriage System

### 1. Conservancy system :

### **a) Garbage:**

- Garbage produced in a particular locality is removed by sweepers by collecting the wastes in wheeled basket.
- They carry the waste to the disposal site or else transfer the wastes to trucks or trollies.
- These truck or trollies further carry it to the disposal site.
- The dry waste are either burnt on the disposal site or dumped in the low level areas.

### **b) sewage :**

- This term is used to indicate the liquid waste from the community and it includes sulage, discharge from latrines, urinals, etc.
- The sewage or night soil is collected from septic tanks of individual houses by the help of sewage tankers and then these are transported to the treatment plant or disposal site.
- The disposal site for sewage disposal must be for city or town area.
- The sewage can be dried in the disposal site to form compost.

### **c) Storm water :**

If heavy rainfall occurs in the city areas, the excess rain water is collected by open drains and is discharged off to river sites or stream .

### **d) Night soil :**

The night soil is collected in pans,then it is carried by labour in trucks,carts etc and then buried into the ground and is thus converted into manure.

### **Disadvantages :**

- Its maintenance cost is very high
- There is chances of pollution of water
- It entirely depends upon the labour.so it shows labour problem
- These are constructed separate from the main building,so it does not permit the compact design.
- It shows land problem for disposal
- If the sewage is not properly disposed ,then there is chances of outbreak of epidemic.

## **2. Water Carriage System (Integrated sewerage system):**

- In this system, the water is used as a medium to convey the sewage to the point of treatment or final destination.
- It is carried by sewer lines.

### **a) Sewage:**

- sewage is carried by under ground sewer pipe lines.
- Plenty of water is necessary to transfer the sewage to the disposal point
- At the disposal point the waste is treated in waste water treatment plant.
- After treatment the waste water is disposed to the river site.
- This type of sanitation system is used for well developed cities .

### **Advantages :**

- This system permits the compact design of building as lavatory is accommodate at any part of the building.
- It is hygienic in nature as sewage is carried out in closed pipe sewer line.
- It requires smaller land for treatment work.

### **Difference between conservancy system and water carriage system**

**of sanitation :**

**Conservancy system:**

- Collection of waste is done by sweepers
- It is unhygienic.
- Requires no water for transfer and disposal .
- Sewage is disposed off without treatment .
- Ground water may be polluted due to open disposal.
- Initial cost is low but maintenance cost is high.
- Conservancy system is applicable for undeveloped cities.
- More area is required for water disposal .
- It does not permit the compact design of structure.

**water carriage system:**

- Collection of waste is done by sewerage network.
- It is hygienic.
- Requires water for transfer and disposal .
- Sewage is disposed off after treatment .
- No chance of contamination of Ground water .
- Initial cost is high but maintenance cost is low.
- water carriage system is applicable for developed cities.
- Less area is required for water disposal .
- It permits the compact design of structure

## **OBJECTIVES OF SEWAGE COLLECTION AND DISPOSAL :-**

The objective of sewage collection and disposal is to ensure that sewage discharged from communities is properly collected, transported, treated to the required degree so as not to cause danger to human health or unacceptable damage to the natural environment and finally disposed off without causing any health or environmental problems. Thus, efficient sewerage scheme can achieve the following:

- To provide a good sanitary environmental condition of city by protecting public health.
- To dispose the human excreta to a safe place by a safe and protective means.
- To dispose of all liquid waste generated from community to a proper place to prevent a favorable condition for mosquito breeding, fly developing or bacteria growing.
- To treat the sewage, as per needs, so as not to endanger the body of water or groundwater or land to get polluted where it is finally disposed off. Thus, it protects the environment from degradation .

## CHAPTER -7

### QUANTITY AND QUALITY OF SEWAGE

The sewage collected from the municipal area consists of wastewater generated from the residences, commercial centers, recreational activities, institutions and industrial wastewaters discharge into sewer network from the permissible industries located within the city limits. Before designing the sewer, it is necessary to know the discharge i.e., quantity of sewage, which will flow in it after completion of the project.

- Accurate estimation of sewage discharge is necessary for hydraulic design of the sewers .
- Since sewers are design to serve for some more future years, engineering skills have to be used to accurately estimate the sewage discharge.

#### **Sources of Sanitary Sewage**

1. Water supplied by water authority for domestic usage, after desired use it is discharged in to sewers as sewage.
2. Water supplied to the various industries for various industrial processes by local authority. Some quantity of this water after use in different industrial applications is discharged as wastewater.
3. The water supplied to the various public places such as, schools, cinema theaters, hotels, hospitals, and commercial complexes. Part of this water after desired use joins the sewers as wastewater.
4. Water drawn from wells by individuals to fulfill domestic demand. After uses this water is discharged in to sewers.

5. Infiltration of groundwater into sewers through leaky joints.

6. Entrance of rainwater in sewers during rainy season through faulty joints or cracks in sewers.

In order to find out a suitable section for the sewer, it is necessary to determine the quantity of sewage that will flow through the sewer. The sewage consists of the following two categories.

i) Dry weather flow

ii) Storm water or wet weather flow

**i) Dry weather flow (D.W.F.):-**

- The flow that occurs during dry seasons in combined system.
- This flow indicates the flow of sanitary sewage.
- This depends upon the rate of water supply, type of area served, economic conditions of the people, weather conditions and infiltration of groundwater in the sewers, if sewers are laid below groundwater table.
- It consists of two types of sewage as follows
  - a. Domestic or sanitary sewage
  - b. Industrial waste

Factors affecting dry weather flow :-

i) Rate of water supply –

- The quantity of sewage depends upon the rate of water supply
- The dry weather flow varies from day to day and also from season to season.

- Generally the rate of flow of sewage is nearly equal to the rate of water supply.
- But practically due to evaporation ,the dry weather flow is 60% to 70% of the rate of water supply.

#### ii) Population :-

- The quantity of sewage generated by a particular city depends on the population of the city.
- If the population of the city is more, then the sewage generated per day is more.

#### iii) Nature of area :-

- The amount of sewage generated depends on the nature of the area.
- The area may be of different nature like residential area or industrial area or rural area etc.

#### iv) Infiltration:-

- The sewage flowing in the sewer line depends on the infiltration rate of that area.
- If the infiltration is less than the storm water produce will be more which will increase the flow through sewer line.

### **Determination of dry weather flow.**

**Q. Write briefly how to determine the amount of sewage as dry weather flow ?**

The quantity of sewage is determined by the following three factors:

- (i) The total sewage produce by a population is considered equal to the amount of water supplied to the population.
- (ii) Additional quantity of sewage is generated by private water supply arrangement, commercial and industrial water usage.
- (iii) Quantity of Dry Weather Flow(D.W.F.)
  - Total water supplied+ additional water supply usage
  - Water evaporated or infiltrated into ground.

## **ii) Storm water or wet weather flow(W.W.F.)**

The amount of sewage that flows through the sewer line during rainy season is known as wet weather flow.

It depends on various factors such as intensity of rainfall, characteristics of catchment area ,duration of storm etc.

Two methods are generally employed for calculating the quantity of storm water for the purpose of designing sewers. These are-

- a. Rational method
- b. Empirical formulas

### **self-cleaning velocity:-**

- It is the minimum velocity which the sewage must flow within the sewer pipe line to avoid any deposition in the sewer line.
- The self- cleaning velocity varies from 70cm/sec—100cm/sec.
- The self-cleaning velocity depends on the amount of waste solid particles and their size.

### **Scouring velocity:-**

Scouring velocity is the velocity beyond the permissible velocity of flow at which the cross section of the sewer line may be damaged.

**Non-scouring velocity:-**

Non-scouring velocity is the maximum permissible velocity with which water can flow without damaging the inner surfaces of the pipe line or sewer line.

**Chezy's empirical formula:-**

$$V=C\sqrt{mi}$$

V=velocity of flow

M=hydraulic mean depth

i=gradient

C=Chezy's constant

**Mannings empirical formula:-**

$$V=\frac{1}{N} \times m^{2/3} \times i^{1/2}$$

Where ,

N-mannings rugosity or roughness

$$Q= A \times V$$

Q= discharge

A=crosssectional area of sewer

V=velocity

$$M = \frac{\text{□□□}}{\text{□ □□□□□□□}}$$

**(Q1.) Determine the diameter of sewer when running full, considering self cleansing velocity of sewer line is 1.6 m/sec, slope 1 in 800 and Chezy's constant 70.**

Given data:-

Self-cleaning velocity (V)=1.6 m/s

Slope or gradient (i) 1 in 800 = 1/800

C= chezy's constant=70

Diameter of sewer ,d=?

We know

$$V = C\sqrt{mi}$$

Where...

$$m = \frac{\text{□□□}}{\text{□ □□□□□□□}}$$

$$\Rightarrow \square = \frac{\square^2}{2\square}$$

$$\Rightarrow \square = \square \frac{\square}{2}$$

So  $V = C\sqrt{mi}$

$$\Rightarrow 1.6 = 70 \sqrt{\frac{r}{2} \times \frac{1}{800}}$$

$$\Rightarrow \left(\frac{1.6}{70}\right)^2 = \left(\sqrt{\frac{r}{2} \times \frac{1}{800}}\right)^2$$

$$\Rightarrow \frac{1.6}{70} = \sqrt{\frac{r}{2} \times \frac{1}{800}}$$

$$\Rightarrow r = (1.6/70)^2 \times 2 \times 800$$

$$= 0.83 \text{ m}$$

Again,  $d = 2r$

$$d = 2 \times 0.8$$

$$d = 1.67 \text{ m}$$

**2. Determine the velocity of flow in a circular sewer of diameter 160 cm laid on a slope of 1 in 650 while running full by using Chezy's formula. Take value of  $c=70$**

Diameter,  $d = 160 \text{ cm} = 1.6 \text{ m}$

Slope,  $i = 1 \text{ in } 650 = 1/650$

$C = 70$

Flow velocity,  $v = ?$

We know

$$V = C \sqrt{mi}$$

Where...

$$m = \frac{\square\square\square\square}{\square\square\square\square\square\square\square\square}$$

$$= \frac{\left(\frac{\square}{4}\right)^2}{\pi d}$$

$$= \frac{\left(\frac{\square}{4}\right)^2 (1.6)^2}{\pi \times (1.6)}$$

$$= 0.4$$

We know

$$V = C\sqrt{mi}$$

$$= 70\sqrt{0.4 \times \left(\frac{1}{650}\right)}$$

$$= 1.736 \text{ m/sec}$$

**3. Calculate the velocity of flow and the discharge through a Sewer of 1 m. laid at a gradient 1 in 500. Assume Sewer running full, use Manning's formula with N=0.012.**

Given data

Diameter of the sewer,  $d = 1 \text{ m}$

Slope or gradient,  $i = 1/500$

$N = 0.012$

Velocity  $v = ?$

Discharge,  $Q = ?$

We know,

$$V = \frac{1}{4} \times m^{2/3} \times i^{1/2}$$

Where

$$m = A/P$$

$$= \frac{\left(\frac{1}{4}\right)^2}{\pi d}$$

$$= \frac{\left(\frac{1}{4}\right)^2}{\pi \times 1} = 0.25$$

$$\text{So } V = \frac{1}{4} \times m^{2/3} \times i^{1/2}$$

$$= \frac{1}{0.012} \times (0.25)^{2/3} \times (1/500)^{1/2}$$

$$= 1.47 \text{ m/s}$$

Again,  $Q = A \times V$

$$= \left(\frac{1}{4}\right)^2 \times \dots$$

$$= \left(\frac{1}{4}\right)^2 \times 1 \times 1.47$$

$$= 1.54 \text{ m}^3/\text{s}$$

**Q- what are the features of sanitary work?**

Ans- The purpose of sanitary work :-

- The purpose of sanitary work is to collect the sewage or garbage.
- Transfer or convert the waste for treatment.
- Treatment of sewage or garbage.

- Disposal of sewage or garbage without affecting the environment.

### **Collect the sewage or garbage:-**

For the collection of sewage , proper sewerage network must be constructed in the city.

- Garbage must be collected by the use of garbage trucks.

### **Transfer or conveyance of sewage and garbage:-**

Sewage is collected and transferred by sewer lines up to sewage treatment plant for treatment . pumps are also used to handle large quantity of sewage .

### **Treatment of sewage and garbage :-**

Various techniques should be used for the treatment of sewage to avoid unhygienic condition during disposal .

- Garbage has to be segregated into decomposable & non decomposable wastes are disposed using proper technique.

### **Disposal of sewage or garbage :-**

The harmful nature of sewage is reduced during treatment and finally disposed of without affecting environment .

- Garbage is recycled into compose or other reusable material.

### **Sewage characteristics:-**

<u>Physical</u>	<u>chemical</u>	<u>biological</u>
-----------------	-----------------	-------------------



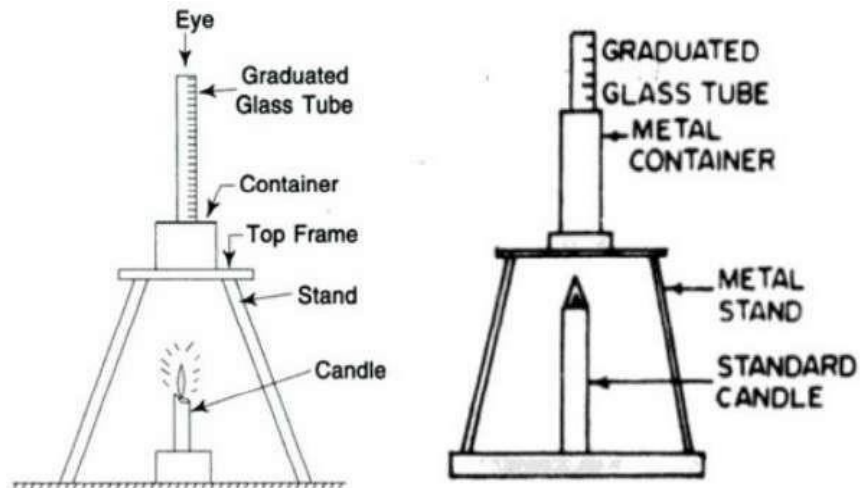

**Jackson's Turbidimeter**

### **Colour:-**

- If the sewage is fresh, it look yellow.
- If the sewage is septic, it looks dark or black.
- Colour can be tested by 'Tinto-meter' using platinum-cobalt scale .

### **Odour: - (smell)**

Sewage has a very foul smelling characteristic .

- From the odour it can be determine the sewage is freshed or septic.

### **Temperature :-**

- The temperature of sewage is little bit higher than the temperature of water supplied.
- The biological activity of bacteria to decompose sewage depends on the temperature of sewage.

## **B.Chemical characteristic:-**

### **(i) Dissolved oxygen:-**

- Dissolved oxygen is the amount of oxygen which is present in the state of dissolved condition in water .
- Sewage consists of large amount of organic matter which require oxygen for decomposition.
- Generally in sewage the amount of dissolved oxygen is almost zero.

### **(ii) Bio-chemical oxygen demand (BOD):-**

- Bio-chemical oxygen demand (BOD) is the quantity of oxygen required by bacteria for the biological decomposition of sewage under aerobic condition.
- BOD is otherwise called as strength of sewage.
- Before disposal of sewage in river or sea water the BOD strength of sewage has to be reduced to protect aquatic or marine life.

### **(iii) Chemical oxygen demand (COD):-**

Chemical oxygen demand is the (COD) is the amount of oxygen required for the chemical decomposition of organic matter in sewage.

- It is the oxygen amount required for oxidation of organic matter.

### **(iv) Nitrogen compounds :-**

- Nitrogen is present in each and every living organism.
- Sewage consist of large amount of nitrogenous compound in the form of free ammonia , albuminoid ammonia, nitrites and nitrates.

- When the sewage is stale it produces free ammonia.
- When sewage decomposition starts it produces albuminoid ammonia.
- When the sewage is under going decomposition it produces nitrites .
- After complete decomposition nitrates are formed which are stable in nature.

(v) **PH:-**

The PH of fresh sewage is above 7 alkaline in nature.

- After decomposition the PH reduces to 5 or 6 (acidic in nature).

**C.Biological characteristics:-**

The sewage consist of large amount of no of micro organisms.

- The micro organisms are like bacteria , fungi, protozoa etc.
- These micro organism decompose the sewage into harmless components.

**Decomposition of sewage :-**

The decomposition of sewage is mostly done by bacteria by the following two process:-

(i) **Aerobic respiration or aerobic decomposition:-**

Aerobic decomposition is the decomposition of organic matter by aerobic bacteria in the presence of sufficient amount of oxygen.

- This process is also called oxidation.

- In this process the organic matter is decomposed into carbon dioxide nitrates and sulphates .

**(ii) Anaerobic respiration or anaerobic decomposition:-**

Anaerobic decomposition is the decomposition of organic matter by bacteria in the absence or limited supply of oxygen .

- This process is called **putrefaction** .
- After decomposition of organic matter compounds like ammonia , mithen gas , hydrogen sulphides and alcohols are formed .

**Cycles of decomposition:-**

**(i) Carbon cycle:-**

Diagram:-

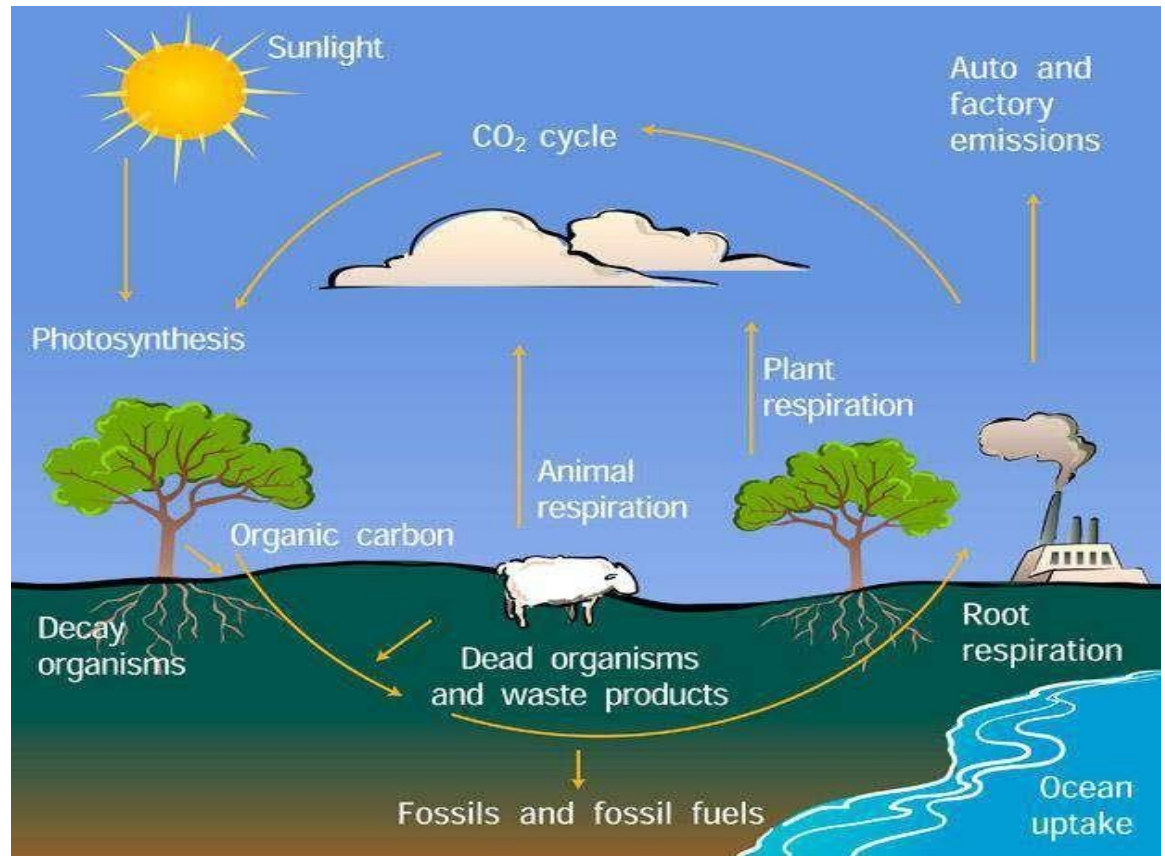

The carbon dioxide from the atmosphere absorbed by the plant during the process of photo synthesis.

- The glucose stored in the plant is consumed in the animals
- The animals stored carbon in the form of fat and other organic matter .

- After the death of animals or plants the organic matter is decomposed by bacteria and again carbon dioxide is released into the atmosphere.
- During respiration animals also release carbon dioxide into the water which is again absorbed by the plant.
- This cycle is known as carbon cycle.

(ii) **Nitrogen cycle :-**

Diagram:-

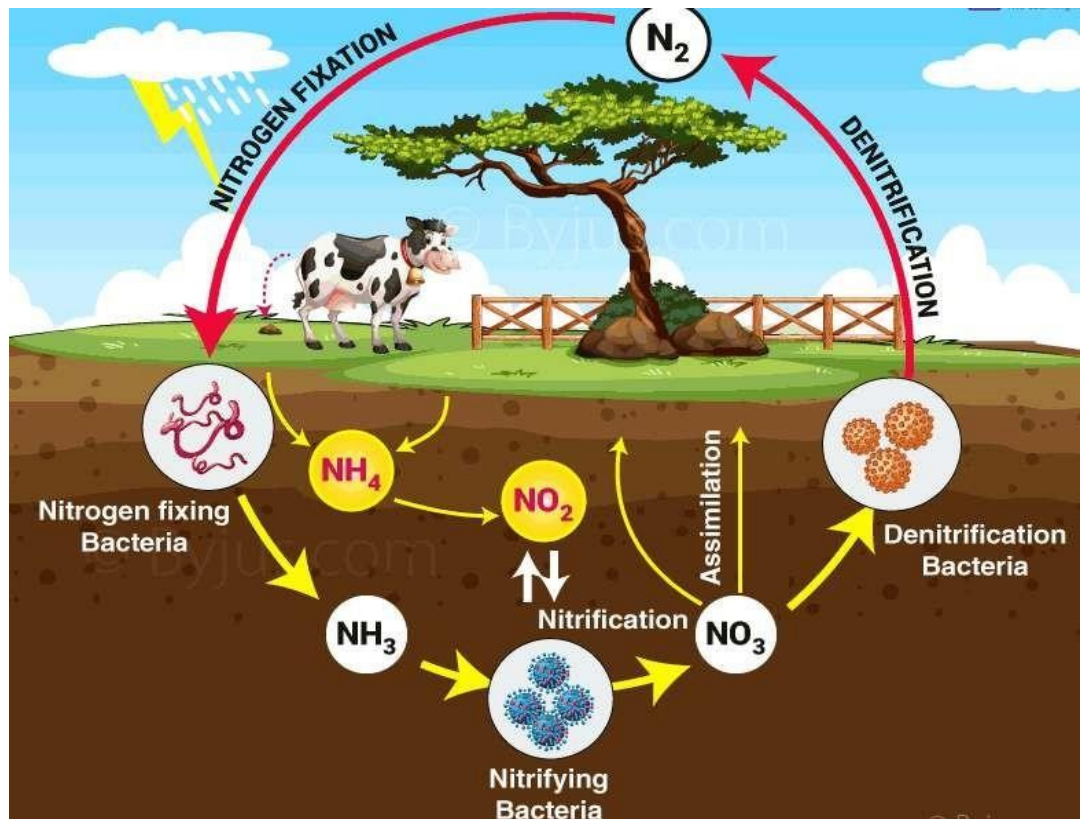

- when dead plant and animals are decomposed by bacteria free ammonia is released .

- free ammonia is then converted into nitrates ,nitrites and nitrogen which is which is consumed by the plants.
- The plants are further consumed by animals in which nitrogen is stored in the form of animal protein .
- After the death of plants and animals the organic matter is again decomposed into free ammonia .
- This cycle is called as Nitrogen cycle.

## CHAPTER-8

### SEWERAGE SYSTEM

**Types of sewerage system :-**

**Following are the three systems of sewerage:**

1. separate system
2. combined system
3. Partially separate system

**1. separate system:**

- In this system two set of sewer are laid. one for carrying sewage and another for carrying storm water.
- The sewage is carried to the plant , the storm water is carried directly to river or storm.

**Advantages :-**

- Load is less
- Natural water is not polluted
- The seware are small
- The storm water is discharged without treatment
- It is economical

**Disadvantages :-**

- The cleaning of sewer is difficult
- The maintenance cost is high
- It is costly

**2. combined system:**

In this system, one sewer is laid, it is both for sewage and storm water . it is carried to treatment plant.

**Advantages :-**

- It is easy to clean , as the sewer size is large
- The maintenance cost is reasonable
- The storm water reduce the strength of sewage by dilution .
- It is economical

Disadvantages :

- Due to heavy storm , the sewer may be overflow.
- If it is not properly designed it gets silted and it became foul in dry weather .
- The road on treatment plant increases
- The storm water is unnecessarily polluted
- It proves uneconomical, when pumping is required for lifting of sewage .

### 3. **Partially separate system:-**

In this system the arrangement is made to permit early washing by rain into sewer carrying sewage . but when the quantity of storm water exceed a particular limit, it is collected and conveyed in open tract to river .

Advantages :-

- The entry of storm water avoid sitting in river
- Disposing of storm water from houses is simple
- The sewer is responsible size

Disadvantages :

- The velocity of flow is low in dry weather
- The quantity of storm water in sewer may increase the load on treatment unit.

## **CONSIDERATIONS FOR THE TYPE OF SYSTEM**

Following points are considered before finalizing the type of collection system :

- The separate system requires laying of two sets of conduits whereas in combined system only one bigger size conduit is required.
- Laying of two separate conduits may be difficult in the congested streets.
- In combined system sewers are liable for silting during non-monsoon season, hence they are required to be laid at steeper gradients.
- Steeper gradients for the sewers may require more number of pumping stations, particularly for flat terrain, which may make the system costly.
- Large quantity of wastewater is required to be treated before discharge in case of combined system.
- Hence, large capacity treatment plant is required.
- In separate system, only sewage is treated before it is discharged into natural water body or used for irrigation.
- No treatment is generally given to the rainwater collected before it is discharge in to natural water body.
- In case of separate system pumping is only required for sewage. Pumping can be avoided for storm water lines, as they are not very deep and normally laid along the natural slopes.

### **Laying of Sewer Pipes**

- Sewers are generally laid starting from their outfall ends towards their starting points. With this advantage of utilization of the tail sewers even during the initial periods of its construction is possible.
- It is common practice, to first locate the points where manholes are required to be constructed as per drawing, i.e., L-section of sewer, and then laying the sewer pipe straight between the two manholes.
- The central line of the sewer is marked on the ground and an offset line is also marked parallel to the central line at suitable distance, about half the trench width plus 0.6 m. This line can be drawn by fixing the pegs at 15 m intervals and can be used for finding out center line of the sewer simply by offsetting.
- The trench of suitable width is excavated between the two manholes and the sewer is laid between them. Further excavation is then carried out for laying

the pipes between the next consecutive manholes. Thus, the process is continued till the entire sewers are laid out.

- The width of the trench at the bottom is generally kept 15 cm more than the diameter of the sewer pipe, with minimum 60 cm width to facilitate joining of pipes.
- If the sewer pipes are not to be embedded in concrete, such as for firm grounds, then the bottom half portion of the trench is excavated to confirm the shape of the pipe itself. In ordinary or softer grounds, sewers are laid embedded in concrete.
- The trench is excavated up to a level of the bottom embedding concrete or up to the invert level of the sewer pipe plus pipe thickness if no embedding concrete is provided. The designed invert levels and desired slope as per the longitudinal section of the sewer should be precisely transferred to the trench bottom.
- After bedding concrete is laid in required alignment and levels. The sewer pipes are then lowered down into the trench either manually or with the help of machines for bigger pipe diameters.
- The sewer pipe lengths are usually laid from the lowest point with their sockets facing up the gradient, on desired bedding. Thus, the spigot end of new pipe can be easily inserted on the socket end of the already laid pipe.

### **Requirements for Sewer Sanitary System Layout Setup**

Following are the several parameters or requirements that should be specified by the design before setting up layout for sewer sanitary system:

- Specify an outlet for sewer sanitary system which is based on the conditions of the project. So, the system might discharge into pumping station, treatment plant, or trunk or main sanitary sewer.
- Estimating tributary area.
- Positioning main sewers and trunk.
- Decide whether pumping station is required or not.
- Specify the location of the pump station, if needed.

### **Setting Up Sanitary Sewer System Layout**

- The initial layout of sewer sanitary system is set up based on the topography of the area and related information. The slope of the sewer system is dependent on the gradient of the area .
- The slope of the sewer system is joined by trunk or main sewers but the exact location is influenced by number of factor such as position of utilities, type and extent of pavement that might be encountered, availability of right of way and traffic conditions.

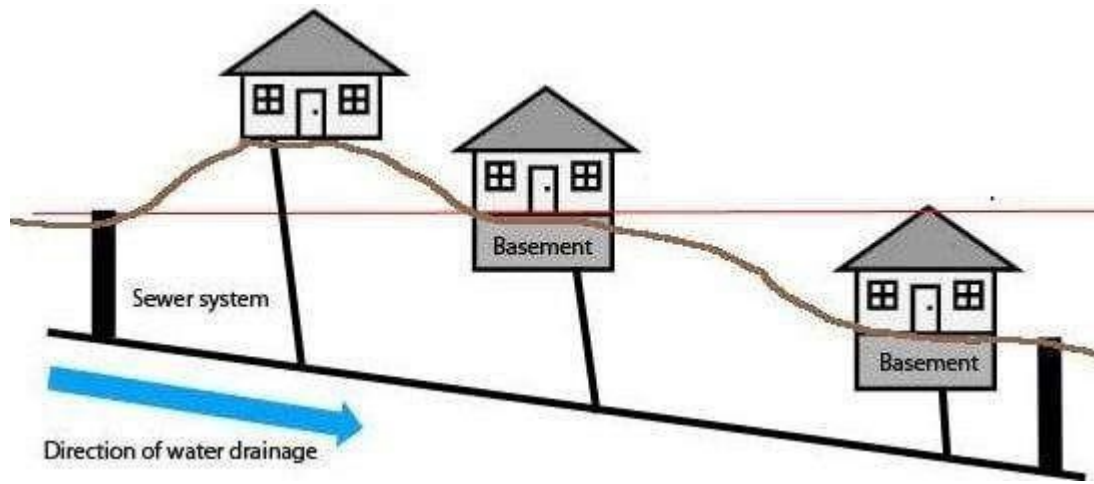

**( Sewer Sanitary Gradient in the Same Direction as Ground Surface or Street)**

- Sewer system drainage district border is governed by separated area, water drainage basin, ridgelines or high points. Sub-district boundaries located in a district is controlled by topography, economy of sewer sanitary layout or any other practical factor that needs considered.
- It should be known that, the need for main, trunk and intercepting sewer sanitary system is not only dependent on the topographical limitations but also construction restrictions. Main, trunk and intercepting sewer sanitary system should be positioned at a lower elevation in a specific area .

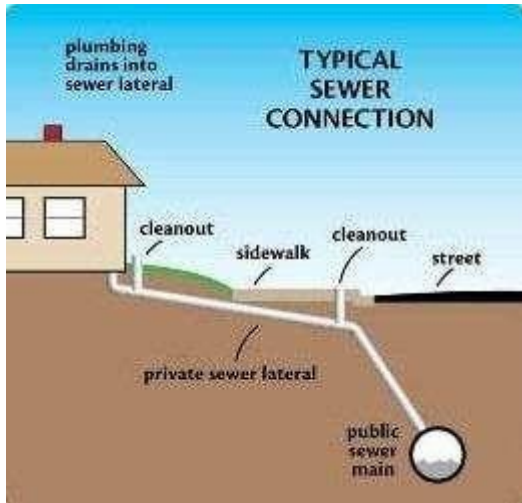

### ( Sanitary Sewer Main Location)

- Sanitary sewer system should be designed in such a way that it takes the future requirements into consideration unless economic restriction prevents the execution of such considerations.
- Regarding the location of sewer sanitary system in relation of public water supplies, almost all codes and state standard specified certain distance between sanitary sewer mains and water mains both horizontally and vertically.
- For example, face to face horizontal distance between water mains and sewer mains should be minimum 3m and vertical distance should be less than 0.45m, and water mains should be located above sewer mains.
- If sewer mains are close to public water supplies, then it is required to take measures into account regarding sewer mains, such as, pressure type sewer pipe should be employed and concrete encasement of sewer pipe should be considered.
- As far as the location of manholes are concerned, they are commonly positioned at sewer sanitary junctions, at any variations in grade, size of the sewer pipe alignments apart from curved alignment and at locations which are provided to offer access to sanitary sewer system for maintenance and emergency purposes as can be observed .

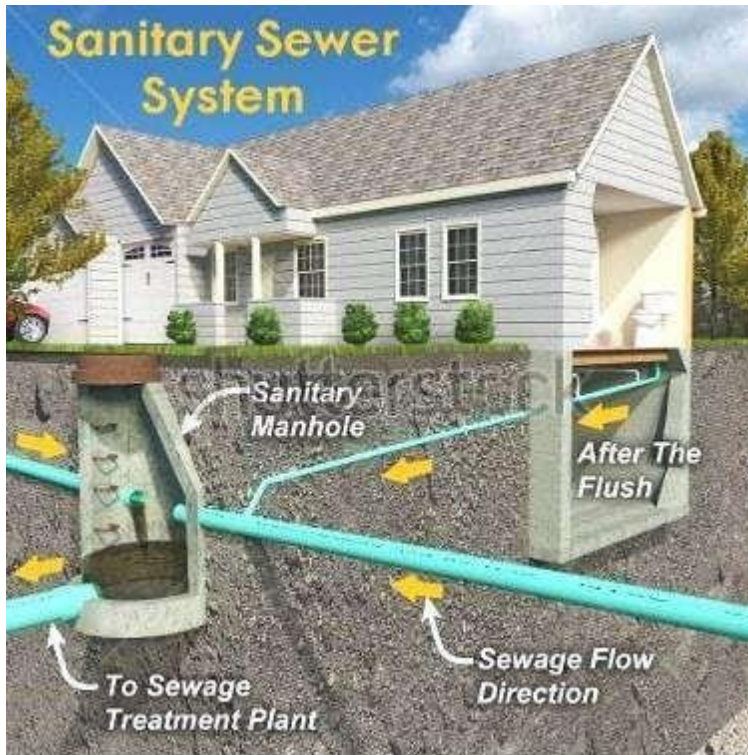

**( Provision of Manholes for Sewer Sanitary System due to Changes in Pipe Sizes)**



**( Provision of Manhole for Maintenance, Inspection and Emergency Purposes)**

- There are recommendations regarding manhole intervals which can be considered for the determination of manhole positions while sewer sanitary system is established.
- These recommendation is based on the diameter of the sewer pipe. For instance, 120m and 150m spacing can be adopted for sewer pipe diameter of 37.5cm and 75cm respectively and larger spacing can be employed for greater pipe diameter.

## **SHAPE OF SEWER :**

Various types of sewers:-

### **(1) Circular sewers :-**

Circular shaped sewers are generally used for collection and transfer of sewage .

Advantages :-

- Its inner surface is smooth and allows uniform flow of sewage .
- There is no chance of deposition of solid particles in the sewer line.
- Circular sewage are easy to connect .

Disadvantages :-

- In case of heavy flow of sewage the circular sewers of smaller diameter are not sufficient . so large diameter of sewage is to be used .

### **(2) Egg shaped section sewers :**

**Egg shaped section sewers are of two types:-**

- a) Normal egg shaped section
- b) Inverted egg shaped section

- The hydraulic mean depth of egg shaped section is same to that of circular sewer section .
- These type of sewer section are sufficient to carry both sewage and storm water .
- This type of sewer are suitable for combine sewer system .



Normal egg shaped section

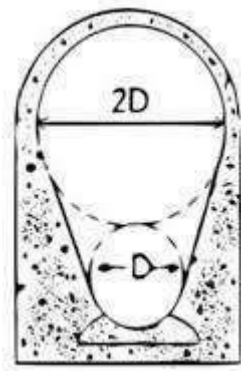

(Inverted egg shaped section)

### 3) Rectangular section sewers:-

- Rectangular section are easy to construct and can carry heavy discharge .
- The maintenance work in rectangular section are easy .
- This can be made up of brick masonry or RCC masonry.



**4) parabolic section sewers :-**

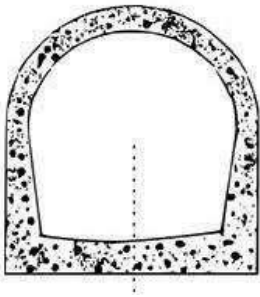

- This type of sewer are suitable for small discharge

**5) Horse-shoe section sewers :-**

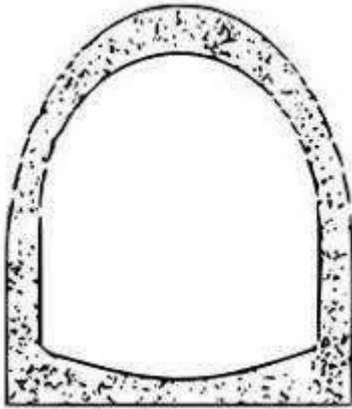

- This type of sewer are constructed to carry heavy discharge , the sewer section looks like a tunnel structure or horse shoe structure .
- The size is kept large for easy maintenance work .

## **Materials of sewer:-**

### **1. Asbestos Cement:**

- For sewerage works, asbestos cement pipes are usually used in sizes ranging from 80 mm to 1000 mm in diameter.
- Standard specifications have been framed by the BIS in IS 6908.
- Non corrosiveness to most natural soil conditions, freedom from electrolytic corrosion, good flow characteristics, light weight, ease in cutting, drilling, threading and fitting with specials, allowance of greater deflection up to 12 degrees with mechanical joints, ease of handling, tight joints and quick laying and backfilling are to be considered.
- These pipes cannot however stand high super imposed loads and may be broken easily.
- They are subject to corrosion by acids, highly septic sewage and by highly acidic or high sulphate soils.
- Protective measures as outlined in corrosion protection in sewers shall be provided in such cases.
- While using AC pipes strict enforcement of approved bedding-practices will reduce possibility of flexible failure.
- Where grit is present, high velocities such as those encountered on steep grades may cause erosion. It is stated that in a recent process of manufacture titled Maaza, high forming pressures of up to 80 kg / sqcm, leading to very smooth surface and very few air pores are possible.
- However, the relevant BIS standard or code of practice is awaited.

### **2. Brick :**

- Brickwork is used for construction of sewers, particularly in larger diameters.
- Many old brick sewers are still in use and the failures are mainly due to the disintegration of the bricks or the mortar joints.

- Because of the comparatively higher cost, larger space requirement, slower progress of work and other factors, brick is now used for sewer construction only in special cases.
- The advantage of brick sewers is that these could be constructed to any required shape and size.
- Brick sewers shall have cement concrete or stone for invert and 12.5 mm thick cement plaster with neat finish for the remaining surface.
- To prevent ground water infiltration, it is desirable to plaster the outside surface.
- Inside plaster can be with mortar using high alumina cement conforming to IS 6452 or polyurea coating and the outer surface shall be plastered with mortar using sulphate resistant cement.

### **3. Concrete:**

- The advantages of concrete pipes are the relative ease with which the required strength may be provided, feasibility of adopting a wide range of pipe sizes and the rapidity with which the trench may be backfilled.
- However, these pipes are subject to crown corrosion by sulphide gas, mid depth water line corrosion by sulphate and outside deterioration by sulphate from soil water.
- These shall be manufactured with sulphate resistant cement and with high alumina coating on the inside at the manufacturers works itself.
- Protective measures as outlined in corrosion protection in sewers shall be provided where excessive corrosion is likely to occur.

### **4. Cast Iron :**

- Cast Iron pipes and fittings are being manufactured in the country for several years.
- These pipes are available in diameters from 80 mm to 1050 mm and are covered with protective coatings.
- Pipes are supplied in 3.66 m and 5.5 m lengths and a variety of joints are available including socket, spigot, and flanged joints.

- These pipes have been classified as LA, A and B according to their thickness. Class LA pipes have been taken as the basis for evolving the series of pipes.
- Class A pipes allow 10 % increase in thickness over class LA.
- Class B pipes allows 20 % increase in thickness over class LA.
- Cast iron pipes with a variety of jointing methods are used for pressure sewers, sewers above ground surface, submerged outfalls, piping in sewage treatment plants and occasionally on gravity sewers where absolutely water-tight joints are essential or where special considerations require their use.
- IS 1536 and IS 1537 give the specifications for spun, and vertically cast pipes respectively.
- The advantage of cast iron pipes are long laying lengths with tight joints, ability when properly designed to withstand relatively high internal pressure and external loads and corrosion resistance in most natural soils.
- They are however subject to corrosion by acids or highly septic sewage and acidic soils.
- Whenever it is necessary to deflect pipes from a straight line either in the horizontal or in the vertical plane, the amount of deflection allowed should not normally exceed 2.5 degrees for lead caulked joints. In mechanical joints, the deflection shall be limited to 5 degrees for 80 to 300 mm dia, 4 degrees for 350 to 400 mm diameter and 3 degrees from 400 to 750 mm diameter pipes.
- Inside coating shall be by Cement mortar and outer coating shall be coal tar both carried out at the manufacturer's works and conforming to the relevant BIS standards/codes of practice.

#### **4. Plastic sewer:**

- Plastic sewer are made from polymers of PVC (POLY VINYLE CHLORIDE)
- These type of pipes are now commonly used for both residential and industrial sewage discharge conveyance.
- Plastic pipes are highly resistant to chemical attacks corrosion .
- This type of sewer lines are available in the market in different diameters.
- These pipes are cheap and economic .

- The joints of plastic pipes are easy to construct.

## 5. Steel:

- Pressure sewer mains, under water river crossings, bridge crossings, necessary connections for pumping stations, self-supporting spans, railway crossing and penstocks are some of the situations where steel pipes are preferred.
- Steel pipes can withstand internal pressure, impact load and vibrations much better than CI pipe.
- They are more ductile and withstand water hammer better.
- For buried sewers, spirally welded pipes are relatively stronger than horizontally welded sewers. The disadvantage of steel pipe is that it cannot withstand high external load. Further, the main is likely to collapse when it is subjected to negative pressure.
- Steel pipes are susceptible to various types of corrosion.
- A thorough soil survey is necessary all along the alignment where steel pipes are proposed.
- Steel pipes shall be coated inside by high alumina cement mortar or polyurea and outside by epoxy.
- Steel pipes shall conform to IS 3589.
- Electrically welded steel pipes of 200 mm to 2,000 mm diameter for gas, water and sewage and laying should conform to IS 5822.

### **Procedure for laying sewer pipes:-**

All the **sewer pipes** are generally laid starting from their outfall end towards their starting.

#### **1) Marking Of The Alignment**

- The center line of the sewer is marked along the road with a theodolite and invert tap.
- It may be marked either by reference line or with the help of sight rail.
- The position of the manhole is also marked.

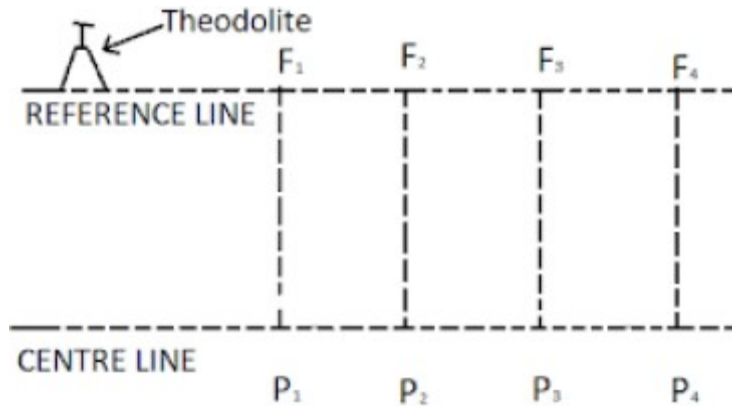

## 2) Excavation of Trenches:

- The work of excavation is usually carried out in the form of open cut trenches but in certain situations as indicated later tunneling is also adopted.
- The excavation is made so as to have trenches of such lengths, widths and depths which would enable the sewers to be properly constructed.
- In busy streets and localities the length of the trench to be excavated in advance of the end of the constructed sewer and left open at any time is usually not more than 18 m.

### **The width of the trench to be excavated is chosen on the basis of two considerations:**

- To facilitate laying and joining of pipe lengths, and
  - (ii) To permit thorough ramming of the backfill material around the pipe.
- At least 20 cm of clear space should be left on each side of the barrel of the pipe so that the minimum clear width of the trench is equal to the external diameter of the pipe plus 40 cm.

- For other types of sewers the minimum clear width should be the greatest external width of the structure to be built therein.
- The depth of the trench should be such as to enable the sewer to be laid at proper grade on the bed of the trench. Suitable recesses are left on the bed of the trench in order to accommodate the socket-end of the pipe sewer.
- However, where the soil is soft it is usual to provide a bed of concrete or a bed of compacted granular material and to rest the sewer thereon, in which case the trench is excavated up to the bottom of such bed to be provided below the sewer.
- The excavation is usually carried out manually through pick axes and shovels. The broken turf, pavement, etc., is carefully stacked out for use in reinstatement. The excavated material is stacked sufficiently away from the edge of the trench to form spoil banks of ordinary size.
- The excavation in roads is done so as to cause minimum of obstruction to traffic and to ensure public safety by erecting suitable warning signals at the site of trenches. Excavation below water table is done after dewatering the trenches.
- The trenches may be excavated either with sloping sides or with vertical sides. Where enough space is available, especially in undeveloped areas or open country, and when the soil is such that vertical sides cannot be sustained, the excavation may be made with sloping sides so that the sides are stable.
- However, in many cases it may be necessary to restrict the top width of the trench and hence the excavation has to be made with vertical sides. When the depth of the trench exceeds 1.5 to 2 m, and when the excavation has to be made with vertical sides which cannot be sustained, it becomes necessary to support the sides of the trench by sheeting and bracing. This operation is known as timbering of trench. There are various methods adopted for timbering of trenches out of which box sheeting is most commonly used.

- Sometimes in place of timbering steel sheeting is adopted in the case of badly water logged areas or in other situations where timber is not easily available. Steel sheeting is more water-tight, stronger and durable, and though costlier than timber, it can be used many times without disintegration and hence more economical in works of larger scale.
- Timbering or sheeting is usually withdrawn after the sewer has been laid, though sometimes it is necessary to leave it off as such particularly in the case of wet trenches which may otherwise be damaged.

### 3) **Bracing of trench:**

- In this process the slide soil slope is supported by the help of bracings , sheet piles or shoring .
- These are made up of timber or steel .
- This is done to protect the trench from getting filled up again by soil .



- It is designed to prevent collapse.

### 4) **Dewatering of Trenches:**

- Where the sub-soil water level is very near the ground surface, the trench becomes wet and muddy because of water oozing in the trench from the sides and bottom.
- In such cases the construction of sewer becomes difficult. As such trenches for sewer construction needs to be dewatered to facilitate the placement of concrete and laying of pipe sewer or construction of concrete or brick sewer and kept dewatered until the concrete foundations, pipe joints or brick work or concrete have cured.

**The various methods adopted for dewatering of trenches are:**

- (i) Direct drainage,
- (ii) Drainage by an under-drain,
- (iii) Sump-pumping and
- (iv) Well-point drainage

**(i) Direct drainage**

Direct drainage is possible by giving a uniform slope to the bottom of the trench and taking out water at some forward point. However, this method is not satisfactory as some water always remains in the trench which, therefore, becomes muddy.

**ii) Drainage by an under-drain**

For drainage by under-drain, an open-jointed tile drain is laid in a small trench 30 cm x 30 cm constructed below the usual trench bed. The under-drain ultimately discharges into a natural water course or into a sump from where water can be pumped. This method is useful provided the trench is not very deep and the under-drain can withstand the load without giving away.

**iii) Sump-pumping**

In sump-pumping water is collected in a sump made out in the trench from where water is pumped. The pump is required to be continuously worked day and night otherwise water keeps on flowing into the trench. This method can be used on small jobs and where the sub-soil strata is not very sandy otherwise sides of the trench are likely to cave in due to continuous pumping.

#### **iv) Well-point drainage**

Well-point drainage is particularly suitable for large jobs and where the sub-soil strata met with consists of 'quick sand' or 'running sand'. The method consists in driving or jetting under water pressure well-points alongside the trench at intervals of 1.5 m or less.

#### **5) Laying and Jointing of Pipe Sewers:**

- Before laying the pipe sewer it should be ensured that the trench has been excavated up to the level of the bottom of the bed of concrete or the bed of compacted granular material if such a bed is to be provided, or up to the invert level of the pipe sewer if no such bed is to be provided.
- Along the trench sight rails are set at intervals of 30 m or so. After setting the sight rails over the trench the centre line of the sewer is transferred to the bottom of the trench by driving small pegs at an interval of 3 m or so.
- For laying the sewer at the desired gradient invert-line of the sewer is set up. This is done by first adjusting the uprights which may be carried out as explained by the following illustration.

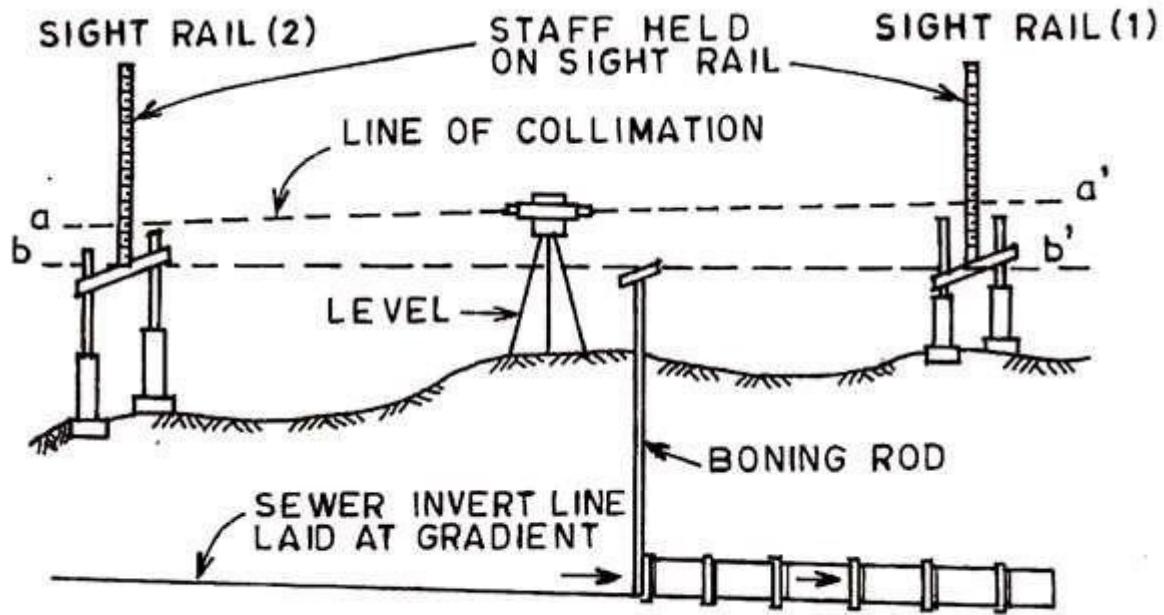

Fig. 5.22 Laying of sewer.

## 6) Testing of leakage of Sewer Pipe Joints

The leakage in the pipe joints or any other points is tested by water test or air test.

### a) Water Test

This test is carried out between two manholes. The lower end of the sewer line is provided with a plug and the upper is kept open. In the manhole at the upper end, water is filled in and it is allowed to flow through the sewer line.

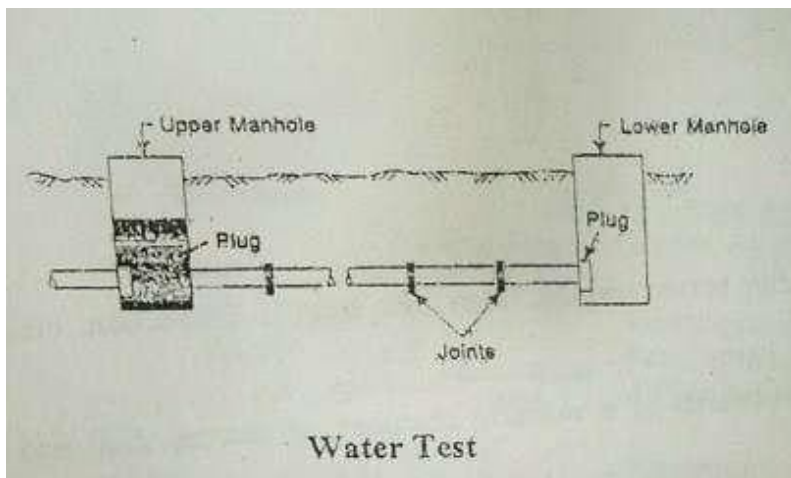

The depth of water in the upper manhole is maintained at about 150 cm. The water is allowed to stay in the sewer for a week. Then the sewer line is inspected to detect the leakage by observing any sweating. If the leakage is detected, it is rectified immediately.

### **b) Air Test**

This test is carried out for large diameter pipe. In this method, the pipe ends of both the manholes are plugged. An air compressor is connected to the plug of upper manhole and pressure gauge is attached with the plug of the lower manhole. The pressure is given in the pipeline by an air compressor and the amount of pressure is recorded in the pressure gauge.

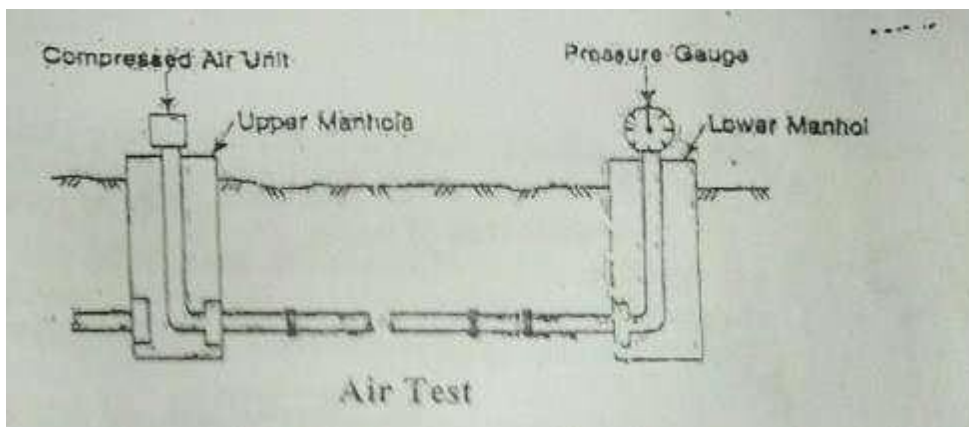

It is left for a few hours. If the pressure drops below the permissible limit, then it is an indication of leakage. The exact point of leakage is found out by applying soap solution which will show bubbles at the point of leakage. If the leakage is detected, it is rectified immediately.

### **7) Back filling :**

- Backfilling is the process of putting the soil back into a trench or foundation once excavation, and the related work has been completed.

- The backfill process requires skills and heavy equipment as well as knowledge of the specifications, contract requirements, and soil conditions.
- The work of backfilling should be carried out with due care, particularly the selection of the soil used for backfilling around the sewer, so as to ensure the future safety of the sewer. The method of backfilling to be used varies with the width of the trench, the character of the material excavated, the method of excavation and degree of compaction required.



## CHAPTER 9

### SEWER APPURTENANCES AND SEWAGE DISPOSAL

#### Introduction

The structures, which are constructed at suitable intervals along the sewerage system to help its efficient operation and maintenance, are called as sewer appurtenances.

These include:

(1) Manholes, (2) Drop manholes, (3) Lamp holes, (4) Clean-outs, (5) Street inlets called Gullies, (6) Catch basins, (7) Flushing Tanks, (8) Grease & Oil traps, (9) Inverted Siphons, and (10) Storm Regulators.

#### Manholes

- The manhole is masonry or R.C.C. chamber constructed at suitable intervals along the sewer lines, for providing access into them.
- Thus, the manhole helps in inspection, cleaning and maintenance of sewer.
- These are provided at every bend, junction, change of gradient or change of diameter of the sewer.
- The sewer line between the two manholes is laid straight with even gradient.
- For straight sewer line, manholes are provided at regular interval depending upon the diameter of the sewer.
- The spacing of manhole is recommended in IS 1742-1960.



## Classification of Manholes

Depending upon the depth, the manholes can be classified as:

- (a) Shallow Manholes,
- (b) Normal Manholes, and
- (c) Deep Manholes

### (a) Shallow Manholes

- These are 0.7 to 0.9 m depth, constructed at the start of the branch sewer or at a place not subjected to heavy traffic conditions .
- These are provided with light cover at top and called inspection chamber.

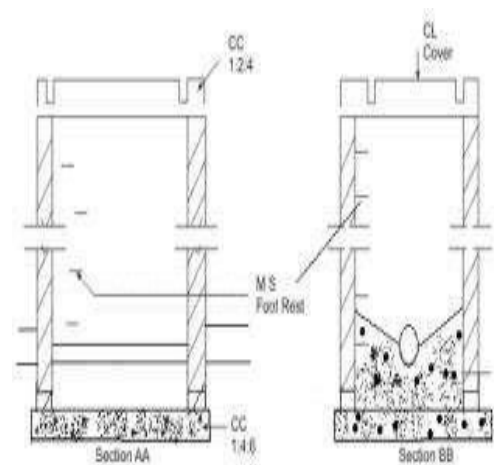

### (b) Normal Manholes

- These manholes are 1.5 m deep with dimensions 1.0 m x 1.0 m square or rectangular with 1.2 m x 0.9 m.
- These are provided with heavy cover at its top to support the anticipated traffic load.

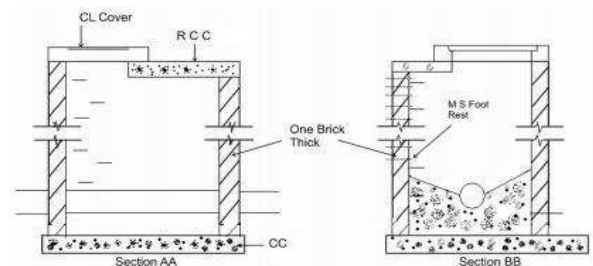

### (C) Deep Manholes:

- The depth of these manholes is more than 1.5 m.

- The section of such manhole is not uniform throughout .
- The size in upper portion is reduced by providing an offset.
- Steps are provided in such manholes for descending into the manhole.
- These are provided with heavy cover at its top to support the traffic load.

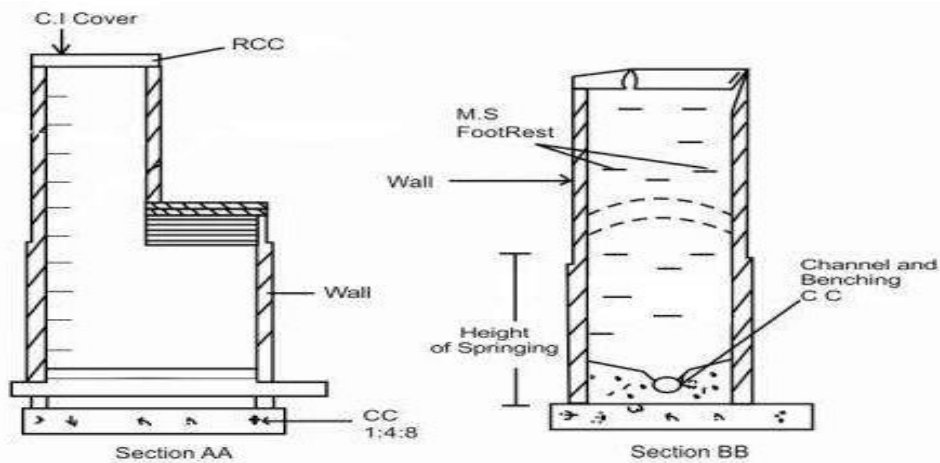

## 2. Drop Manholes

- A drop manhole is a type of manhole which is constructed on a sewer line where a sewer at a high level is to be connected to another sewer at a lower level.

Such situations may arise as indicated below:

- Branch sewers are generally situated at lower depths below the ground level whereas main sewers are laid at greater depths below the ground level.
- When a branch sewer located at a higher level is to be connected to a main sewer located at a lower level then if ordinary manhole is provided

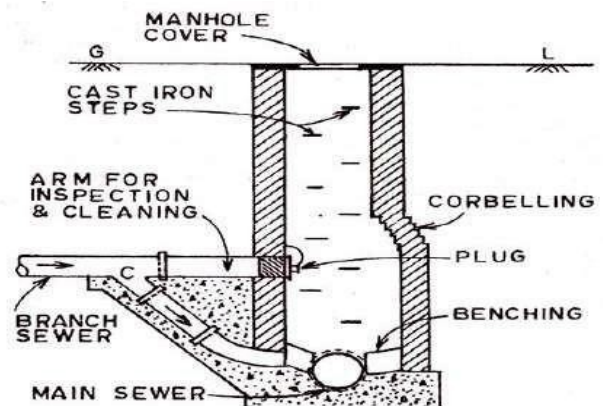

Fig. 6.9 Drop manhole with a ramp or inclined drop pipe

the sewage from the branch sewer will fall from above into the manhole which is not desirable and is to be avoided.

- Thus, at the junction of branch sewer and main sewer when the difference between the invert level of branch sewer and peak flow level of main sewer is more than 600 mm a drop manhole is provided.
- The construction of drop manhole permits the sewage from branch sewer to be discharged at the bottom of the manhole without necessitating steep gradient for branch sewer and thus reduces the quantity of earth work.

### 3. Lamp-Holes:

- Lamp-holes are small openings provided on sewer lines mainly to permit the insertion of a lamp into the sewer for the purpose of inspection of sewer lines and detecting the presence of any obstructions inside the sewers.

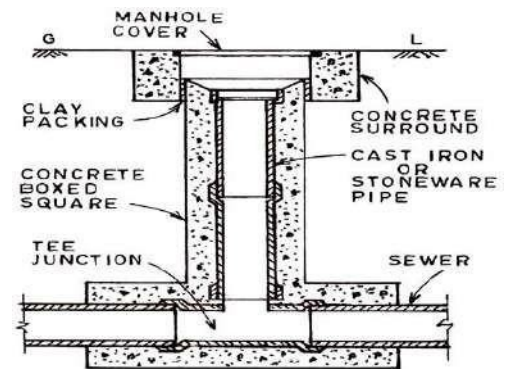

- A lamp-hole consists of a vertical stone ware or concrete or cast iron pipe 225 to 300 mm diameter, connected to the sewer line through a 'T' junction.
- The pipe is surrounded by concrete to make it stable.
- At the ground level the lamp-hole is provided with a manhole cover with frame strong enough to take up the load of traffic.
- The manhole cover with frame is carried on a concrete-surround which is separated from the lamp-hole by 15 cm vertical clay joint and thus permits the concrete-surround to bear the traffic load passing on the cover without

causing the pipe-column to be subjected to heavy loads resulting in its possible collapse.

Purposes of using Lamp holes

(i) Inspection:

- For inspection of sewer line an electric lamp is inserted in the lamp-hole and the light of the lamp is observed from the two manholes one upstream and the other downstream of the lamp-hole.
- If the sewer length is unobstructed, the light of the lamp will be seen.

(ii) Flushing:

- Under certain circumstances ,when no other flushing devices are available, lamp-holes may be used for flushing the sewers.

(iii) Ventilation:

- If the cover at the top of the lamp-hole is perforated the ventilation of the sewer is affected.
- Such a lamp-hole is also known as fresh-air inlet.

Lamp-holes are found suitable for use under the following situations:

(1) A lamp-hole may be provided when there is change in the alignment or gradient of the sewer line between two manholes that are a short distance apart.

(2) When the sewer is straight for a considerable distance beyond the usual spacing of manholes a lamp-hole may be provided.

(3) When the construction of a manhole is difficult, a lamp-hole may be provided in the place of manhole.

It may, however, be noted that the lamp-holes have become more or less obsolete and hence at present times these are rarely provided.

#### **(4) Clean-outs**

- A drain cleanout provides access to your main sewer line and is located outside of your home in the front or back yard.
- Cleanouts typically go unnoticed until there is a problem.
- They look like capped pipes sticking a few inches above the ground.
- Clean-outs are the devices meant for cleaning the sewers.
- These are generally provided at the upper ends of lateral sewers in place of manholes.
- A clean-out consists of an inclined pipe, one end of which is connected to the underground sewer and the other end brought up to ground level.
- A cover is provided at the top end of the clean-out pipe at the ground level.
- For cleaning the sewer the cover of the clean-out pipe is removed and water is forced through clean-out pipe to the sewer to remove obstacles in the sewer.
- If obstructions are large enough, flexible rod may be inserted through the clean-out pipe and pushed backward and forward to remove such obstacles.



## (5) Street inlets called Gullies

- Inlets are the devices meant to admit storm water (or rain water) and surface wash flowing along the roads/streets and convey the same to storm water sewers or combined sewers.
- An inlet is a small box like chamber made of brickwork or concrete, having an opening at the top in vertical or horizontal direction for the entry of storm water (or rain water) and surface wash.
- The water from this chamber leaves through an outlet provided at its bottom and carried by a pipeline to a nearby manhole.
- Inlets are of 3 types
  - i. Curb inlets
  - ii. Gutter inlets
  - iii. Combination inlets



### i) Curb Inlets:

- Curb inlets (also called vertical inlets) have vertical openings in the road curbs through which storm water flows.



- The openings are provided with gratings of closely placed bars.
- These inlets are preferred where heavy traffic is anticipated.
- The curb inlets are termed as deflector inlets when equipped with diagonal notches cast into the gutter along the curb opening to form a series of ridges or deflectors.
- The deflector inlet also does not interfere with the flow or traffic as the top level of the deflectors lie in the plane of the pavement.

### ii) Gutter Inlets:

- Gutter inlets (also called horizontal inlets) have horizontal openings in the gutter which are covered by gratings through which storm water flows.



- The clear opening between the bars of the gratings should not be more than 25 mm and the gratings should be capable of sustaining heavy traffic loads.

### iii) Combination Inlets:

- Combination inlets are composed of a curb and gutter inlet acting as a single unit.
- Normally, the gutter inlet is placed right in front of the curb inlet but it may be displaced in an overlapping or end-to-end position.
- Each of the above noted three types of inlets may be either undepressed (or flush) or depressed



depending upon their elevation with reference to the pavement surface.

- The depressed inlets may, however, result in some interference with traffic.
- The inlets are usually located by the side of the roads.
- Maximum spacing of inlets depends on conditions of road surface, size and type of inlet and rainfall.
- A maximum spacing of 30 m may be adopted for locating the inlets.

### **(6) Catch basins or catch pit**

- A catch basin or catch pit is a device meant for the retention of heavy debris in storm water which otherwise would be carried into the sewer.



- It is an inlet with its outlet being placed well above its bottom so that heavy debris such as grit, sand, etc., flowing along with storm water is allowed to settle down and thus prevented from entering the sewer.
- The outlet from the basin is provided with a hood or it is trapped to prevent escape of foul gases from the sewer and to retain floating matter.
- At the bottom of the basin space is provided for the accumulation of the settled matter.

### **7) Flushing Devices:**



- When sewers are to be laid in a flat country, it is not possible to obtain a self-cleansing velocity even once a day due to flatness of gradient especially at the top ends of branch sewers which receive very little flow.
- Similarly near the dead ends of the sewer lines, the self-cleansing velocities cannot be achieved because the discharge coming at the starting point happens to be small.
- In both these cases the discharge is required to be increased and this is done by adding a certain quantity of water by means of flushing devices.
- Thus, flushing devices help to prevent clogging of sewers and permit the adoption of flatter gradients than those required to maintain self-cleansing velocity

The various flushing devices may be broadly classified under the following two categories:

- (1) Hand operated flushing devices; and
- (2) Flushing tanks.

### **(8) Grease & Oil traps**

- Grease and oil traps are the chambers provided on the sewer line to exclude grease and oil from sewage before it enters the sewer line.
- These are located near the sources contributing grease and oil to sewage, such as automobile repair workshops, garages,



kitchens of hotels, grease and oil producing industries, etc.

**It is essential to exclude grease and oil from sewage due to following reasons:**

(i) If grease and oil are allowed to enter the sewer, they will stick to the inner surface of the sewer and will become hard, thus cause obstruction to flow and reduce the sewer capacity.

(ii) The suspended matter which would have otherwise flown along with sewage will stick to the inner surface of the sewer due to sticky nature of grease and oil, thus further reduce the sewer capacity.

(iii) The presence of grease and oil in sewage makes the sewage treatment difficult as they adversely affect the bio-chemical reactions.

(iv) The presence of a layer of grease and oil on the surface of sewage does not allow oxygen to penetrate due to which aerobic bacteria will not survive and hence organic matter will not be decomposed. This will give rise to bad odours.

(v) The presence of grease and oil in sewage increases the possibility of explosion in the sewer line.

## **9. Inverted Siphons**

- An inverted siphon is a section of sewer which is constructed lower than the adjacent sections to pass beneath a valley, river, stream, road, railway and such other obstructions.
- It runs full at greater than atmospheric pressure because the crown is depressed below the hydraulic grade line.

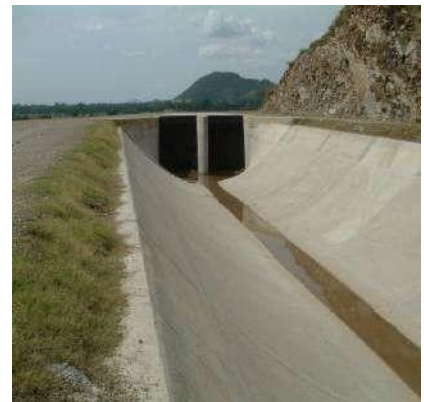

- An inverted siphon differs from a true siphon in this respect that whereas a true siphon flows full with the flow-line above the hydraulic grade line and, therefore, under pressure less than atmospheric, an inverted siphon runs full with the flow-line depressed below the hydraulic grade line and, therefore, under pressure above atmospheric.
- For this reason inverted siphons are frequently referred to as depressed sewers.

### 10. Storm Water Overflow Devices or Storm Water Regulators:

- In the case of combined system of sewerage a large quantity of storm water (or rain water) flows through the sewer along with domestic sewage.
- Usually it is neither advisable nor practicable, to pump and/or treat such a large quantity of sewage.



- Moreover, the percentage of domestic sewage in a combined system is very much less, and hence the domestic sewage gets diluted by storm water to a considerable extent.
- It is, therefore, possible to divert a portion of this combined sewage and discharge it into a watercourse such as stream, nalla, river, etc., without any trouble.
- This is achieved by providing storm water overflow devices or storm water regulators in an intercepting sewer so that the outfall sewer will carry only a portion of the combined sewage to the sewage treatment plant.

- For example – if the combined sewage is 6 times dry weather flow, 3 times dry weather flow will be taken for treatment as in the case of a separate system of sewerage and the remaining 3 times dry weather flow will be discharged directly into a water course.
- Thus storm water overflow devices or storm water regulators are the devices which are provided in a combined system of sewerage to permit the diversion of excess sewage through relief sewer to a watercourse and thus prevent overloading of sewers, pumping stations, treatment plants or of disposal arrangements.

Following are the three types of storm water overflow devices or storm water regulators:

- (1) Side flow weirs or overflow weirs
- (2) Leaping weirs or jumping weirs
- (3) Siphon spillways.

### **Disposal on land or Land Disposal**

- Land disposal can be either in or on the ground – in a land fill, injection well, or other land-based unit.



- Currently , about 23 million tons of hazardous waste are land disposed each year in the world .
- A wide range of wastes and by- products of industrial process is being spread on the land in agriculture, forestry and land reclamation operation.



### **Types of wastes**

The wastes are of generally following types :-

- Animal manures .
- Waste from food and drinks preparation (sugar beet processing , meat and fish processing dairies , vegetable processing etc).
- Blood and gut contents from abattoir.
- Waste lime from cement manufacturer and gas processing .
- Waste from basic organic chemical and pharmaceutical companies .
- Paper waste sludge , waste paper and de-inked paper pulp.
- Sludge from portable water production .
- Waste from leather and tannery industry .
- Slag from steel industry .
- Sewage
- Municipal wastage

]

## Disposal method

- Selecting a disposal method depends almost entirely on costs, which in turn are likely to reflect local circumstances. These are:-

1. Land fill
2. Waste buried in soil



## Land fill

- Disposal of solid wastes on land is by far the most common method in the most of the countries and probably accounts for more than 90 percent of the world's municipal refuse.
- Sanitary landfills is the cheapest satisfactory means of disposal, but only suitable land is within economic range of the source of wastes; typically collection and transportation account for 75% of total cost of solid waste management.
- In a modern landfill, refuse is spread in thin layers, each of which is compacted by a bulldozer before the next is spread



## Sewage Farming:

- When the sewage is used for growing crops, it is called sewage farming.
- The fertilized elements of sewage are consumed by the root of crops.

- The minerals , nitrates , sulphates and phosphates are main fertilizer constituents of sewage .
- The method in addition to disposing of sewage may also help in increasing crop yield by 30% and so.



- Sewage farms use sewage for irrigation and fertilizing agricultural land.
- The practice is common in warm, arid climates where irrigation is valuable while sources of fresh water are scarce.
- Suspended solids may be converted to humus by microbes and bacteria in order to supply nitrogen, phosphorus and other plant nutrients for crop growth.

- Many industrialized nations have implemented conventional sewage treatment to reduce vector and odour problems for water reclamation and use of biosolids; but sewage farming remains an option for developing countries.



### **ADVANTAGES:**

- Sewage farming allows use for irrigation of water which might otherwise be wasted.
- Some of the nutrients and organic solids in wastewater can be usefully incorporated into soil and agricultural products rather than fouling natural aquatic environments.

- Pumping to the point of application may be the only requirement if the village is not at a higher elevation than the sewage farm.

### **DISADVANTAGES**

- Polluted runoff may occur from sewage irrigation of fields when entering wastewater and precipitation exceed evaporation and percolation capacity.
- Sewage is usually generated at a relatively constant rate, but irrigation is required only during dry weather, and is useful only while temperatures are high enough to promote plant growth.
- Over-irrigation causes soils to become septic, sour, or *sewage-sick*.
- Arid climates may allow temporary storage of sewage in holding ponds while the soils dry out during non-growing seasons, but such storage may cause odor and aquatic insect problems, including mosquitoes.

### **Sewage sickness**

- If sewage is applied continuously on a piece of land, pores or voids of soil are filled up or clogged.
- Free circulation of air is thereby prevented and anaerobic conditions develop.
- At this stage, the land is unable to take any further sewage load.
- Organic matter decomposes and foul smelling gases are produced.
- This phenomena of soil are known as sewage sickness of land.



## **Disposal of sewage by dilution**

- Dilution is the disposal of sewage by discharging it into large bodies of water like stream, sea, river etc.
- This method is possible when natural water is available in large quantity near the town.
- Proper care should be taken while discharging sewage in water so that sewage may not pollute natural water and make it unfit for any other purposes like bathing, drinking, irrigation etc.
- In this process, the raw sewage or the partially treated sewage is thrown into natural waters having large volume.
- The sewage in due course of time is purified by what is known as the self-purification capacity of natural waters.
- The limit of discharge and degree of treatment of sewage are determined by the capacity of self-purification of natural waters.



## **Conditions favorable for dilution**

Following conditions are favorable for sewage to be disposed off by dilution into natural waters :-

- It is possible only to provide primary treatment to sewage i.e., removal of floating matter and settleable solids.



- Currents of flow of diluting waters should be favourable which means that nuisance should not be caused when sewage is discharged into diluting waters.
- Diluting waters are not used for the purpose of navigation for at least some reasonable distance on the downstream from the point of sewage disposal.
- Diluting waters should not have habitation or they should not have been used as source of water supply for at least some reasonable distance on the downstream from the point of sewage disposal .
- Dissolved oxygen content of diluting waters should be high
- The place is situated near natural waters having large volumes.
- The sewage is relatively fresh and it is possible to bring it to the point of discharge within four or five hours of its production.

## Chapter 10

### Sewage treatment

#### Sewage treatment

Sewage treatment is done in two stages :

- 1.Primary treatment of sewage
- 2.Secondary treatment of sewage

#### 1.Primary treatment of sewage

Flow chart of Primary treatment

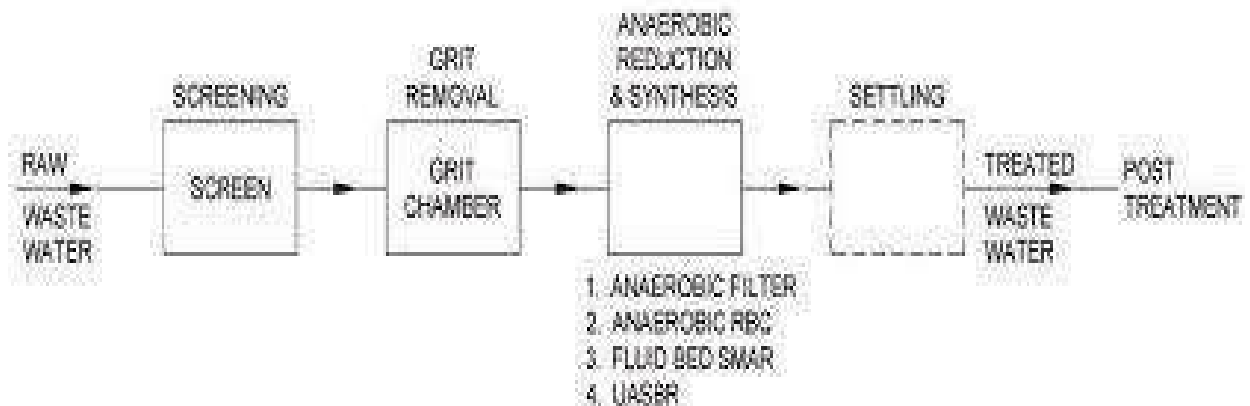
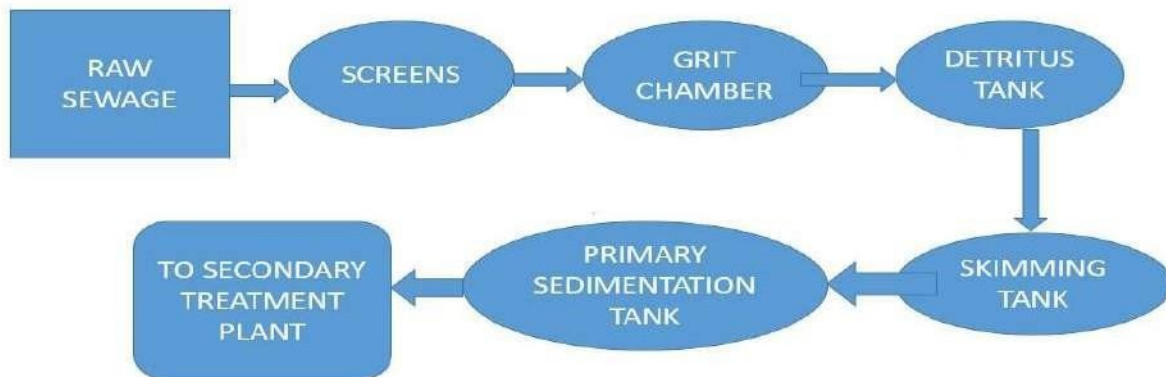

## Screens :

- Screens are made up of mild steel rods or gratings at a spacing of 40mm to 6 mm .
- The purpose of screens is to retain large floating material from the sewage .
- It is kept at an angle of 30 degree to 60 degree against the flow of sewage.



## Grit Chamber :

- Grit chamber consist of a rectangular brick masonry tank .
- The purpose of grit chamber is to remove grit particles like sand ,fine gravels flowing in the sewage .
- The velocity of flow of sewage in the grit chamber is 20 cm- 30 cm per second.
- The solid grit matter settles down as a sludge which can be removed by a removal pipe at the bottom of the grit chamber.

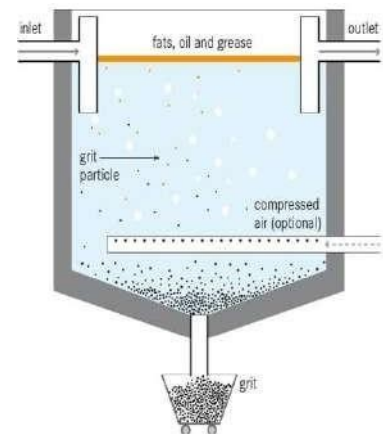

## Detritus Tank :



- Detritus tank is the rectangular tank which is used for the settlement of fine particles .
- The length of the detritus tank varies from 20cm-40cm and its depth varies from 2m-3m.
- The velocity of sewage flow is kept between 15-20 cm/sec .
- The cleaning of the detritus tank is done manually at periodic interval .

### **skimming tank :**

- Skimming tank is a rectangular brick masonry tank in which grease and oil from sewage are separated by the use of air diffuser .
- The air diffuser are provided at the bottom of the tank from which compressed air is passed into the sewage which removes the oil and grease from the sewage .
- Proper outlet is provided to allow the separated sewage into the primary sedimentation tank .
- The oil and grease are trapped inside the skimming tank .

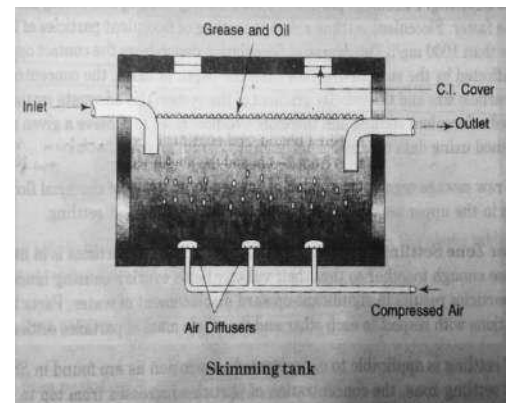

### **Primary sedimentation tank :**

- Primary sedimentation tank is the last tank of primary treatment.
- Primary sedimentation tank is a rectangular tank which is made up off brick masonry tank.



- Baffle walls are provided in the primary sedimentation tank to reduce the velocity of flow.
- This tank gives sufficient opportunity for all fine particle and organic matter to settle down.
- The sludge settled at the bottom of the tank is removed periodically by manual operation .

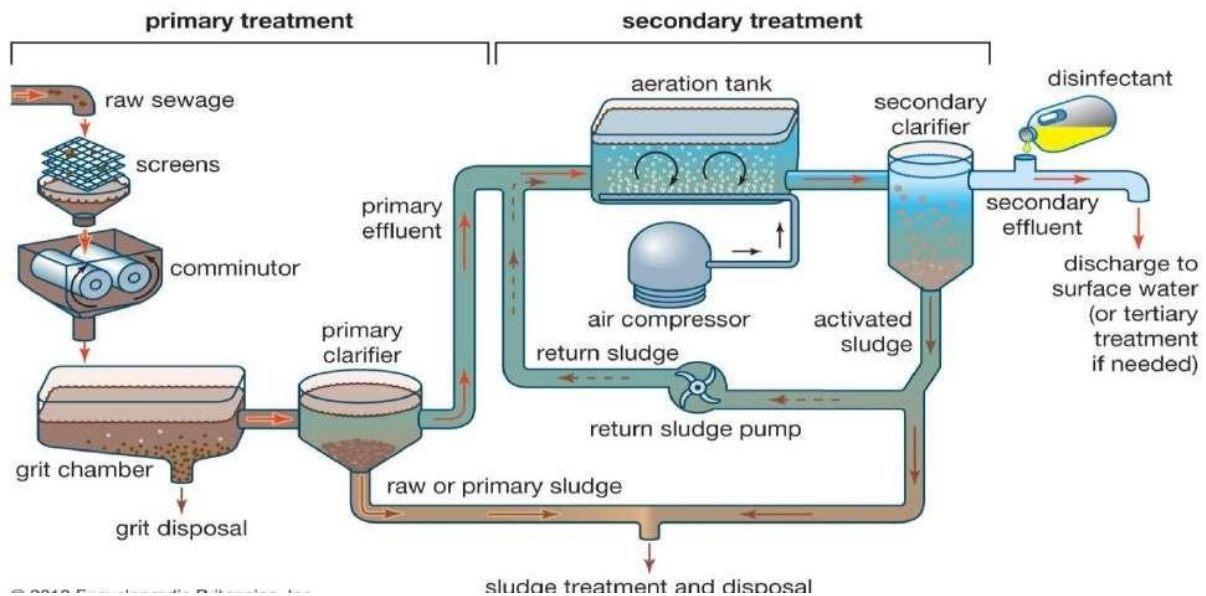

## 2. Secondary treatment of sewage

- After primary treatment, the sewage water is subjected to the next phase called biological treatment or secondary treatment.
- Dissolved and suspended biological materials are removed by indigenous microbial decomposition in a managed environment.

In this treatment, BOD is reduced up to 90-95%.

- Biological treatment is carried out in two important phases:

### 1. Aerobic phase:

a.oxidation lagoons,

b.trickling filters,

c.activated sludge

### 2. Anaerobic phase:

a. sludge digestion

## A. Oxidation lagoons /oxidation ponds / stabilization ponds

- 1.It is outdoor, simple, suspension type aerobic treatment.
- 2. It is suggested for small societies in rural areas where sufficient low lying land of little real state value is available.

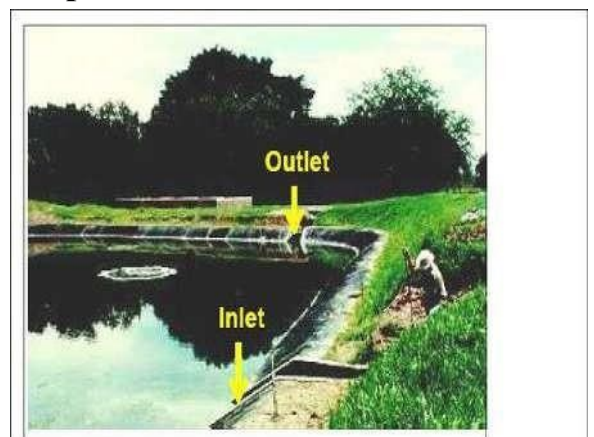
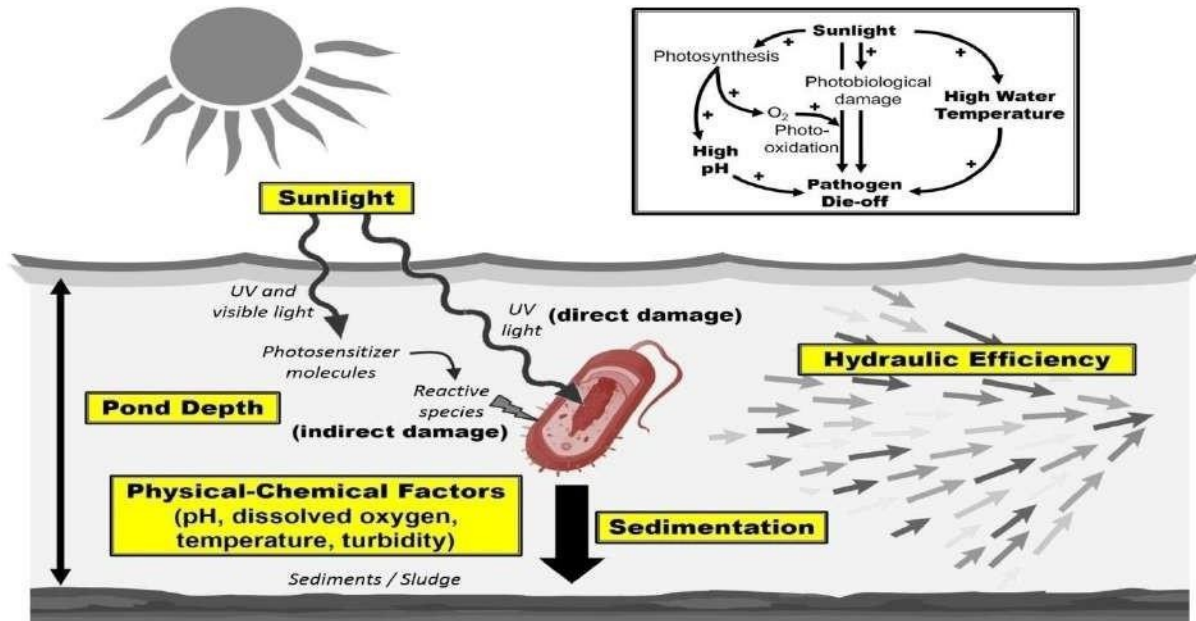

Figure 14. An example of poor inlet and outlet arrangements in an anaerobic pond. They are located in adjacent corners of the pond rather than in diagonally opposite corners, leading to hydraulic short-circuiting.

- 3. It is oldest of the sewage treatment systems used in most of developing countries due to its low cost.
- 4. The shallow pond is required which should be maximum of 10 feet depth having inlet and outlet.



### Requirements of Oxidation pond

1. Presence of algal growth which produces oxygen.
2. Oxygen is also available from atmosphere.
3. Heterotrophic aerobic and anaerobic microbes for decomposing sewage.
4. Sunlight required for photosynthesis, also has bactericidal properties (UV).



### Advantages of oxidation pond

1. It is Simple
2. It is Inexpensive
3. It has Low maintenance

#### Disadvantages of oxidation pond

1. Effected by environment: low temperature, cloudy sky lowers efficiency
2. Takes longer time(Long retention time)
3. Gives bad odour( $H_2S$ )
4. Not hygienic
5. Just lowers BOD by 25%to 60%

#### **B. Trickling Filter Method**

1. It is also outdoor, aerobic, relatively simple but of film flow type.
  2. It consists of large cylindrical ,concrete tank of diameter:8-16m and depth:2-3m
  3. Tank is filled with porous bed of crushed stones ,rocks , clinker etc.
  4. Void age= $\frac{\text{total air space in bed}}{\text{total bed volume}} \times 100 = 45-55\%$  to prevent clogging.
- . Sewage enter through inlet, reaches to sprinkler.
- As its arms rotate, sewage is sprayed on the porous bed.



- Below the porous bed ,network of drain pipe is present.

6. The treated sewage trickles (so called trickling filter) to the bottom, collects in a depression called slump From there, single main outlet carry treated sewage effluent.



7. Rotating arms of sprinkler spray sewage which helps to saturate the sewage drops with oxygen.

8. As sprinkling is intermittent, sewage gets enough space and time to percolate and system maintain aerobic conditions. (Spraying is not continuous).

9. As sewage trickles, microbes in sewage colonize the surface and form microbial film.

10. The surface becomes covered with aerobic microbial population comprising of bacterial species including, Beggiatoa, Flavobacterium, Achromobacter, Zooglea and Pseudomonas, microalgae, microfungi and protozoa etc.

11. In this, slime producing bacteria plays a very important role.

Zooglea ramigera since it is main microbe,the film is called Zooglea film.

- With time ,film becomes thicker and thicker.

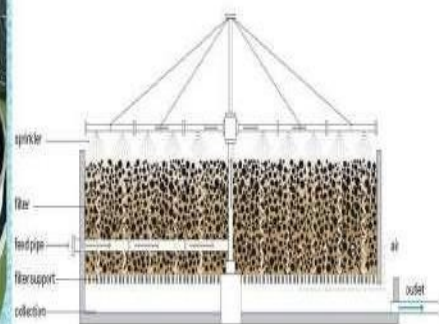

12. After sometime, the oxygen and nutrients cannot reach innermost cells and they die and film gets clogged off.

-> This can block the pores and untreated sewage starts accumulating on the top.

- Then porous bed has to be changed.

Advantages of trickling filter

1. Lowers BOD of sewage by 75-85%
2. Efficiency can be increased further by using series of such filters
3. Relatively cheaper
4. Easy to operate
5. Advance than oxidation pond

Disadvantages

1. Porous bed has to be changed periodically due to clogging .
2. Efficiency effected by environment.
3. During spraying aerosols are formed that help in spread of pathogen.

### **C. Activated sludge process**

1. It is highly advanced, indoor, aerobic and suspension type.
2. Raw sewage after primary treatment is introduced in large tank called aeration tank.



3. Sewage is vigorously aerated and agitated in the presence of activated sludge.
4. This sludge has been taken from previous run and consists of microbial flocs which are aggregates of micro-organism in the slime.

5. Agitation and aeration can be brought by two ways:

- a. From the bottom by bubble diffuser(air injection)
- b. By mechanical devices called paddle stirrer

6. Microbial activity is maintained at high levels by reintroduction of most of the settled activated sludge, hence names as activated sludge process.



7. Following aerobic microbial decomposers develop biological floc that decomposes organic matters into simple soluble molecules, amino acids, ammonia, phosphorus, nitrates, CO<sub>2</sub>, H<sub>2</sub>O etc.

- a. Bacteria: Enterobacter, Achromobacter, Flavobacterium, Pseudomonas, Zooglia, Micrococcus, Sphaerotilus, Beggiatoa, Thiobacillus etc.
- b. Protozoa: Amoeba, Paramecium and Volvox.
- c. Filamentous fungi: Geotrichum, Cephalosporium, Penicillium and Cladophorium.
- d. Yeast: very low number

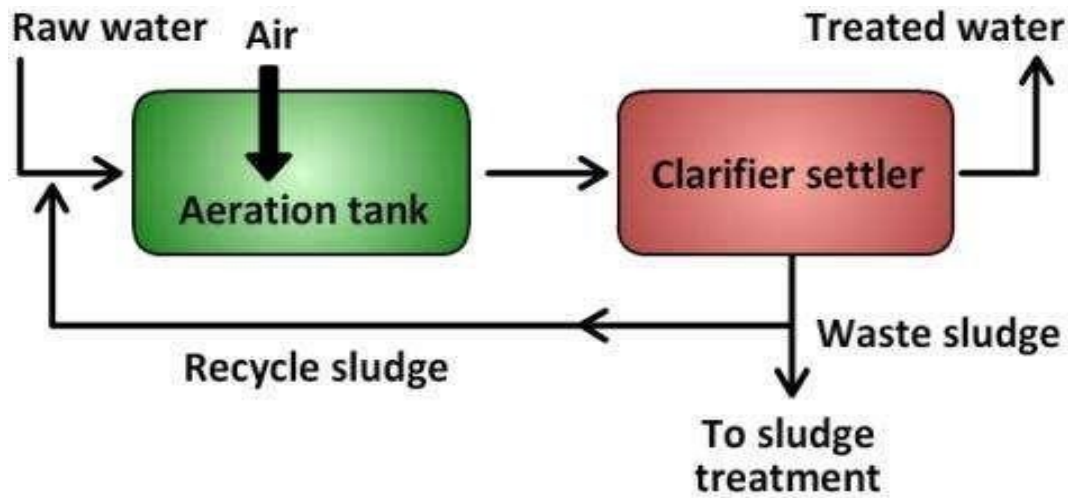

## 2. Anaerobic phase:

### a. sludge digestion

Example:

#### A. Septic tank :-

Septic tank is an anaerobic digestion tank usually employed for the treatment of sewage discharged from the communities or residential quarters where population is less and sufficient land is available.

A septic tank is made of metal or concrete that achieves two goals:

1. Sedimentation of solid materials
2. Biological degradation of settled solid materials.

- As sewage enters the tank, sedimentation of solid materials occur in the bottom of the tank named sludge which undergo



anaerobic decomposition through the action of anaerobic bacteria that degrade solid organic compounds to simpler and soluble compounds.

- The collection pipelines of septic tanks should be checked regularly to avoid any leakage near residential area as it may contaminate the drinking water pipelines if they damaged.
- Septic tank treatment cannot guarantee elimination of all pathogenic microorganisms.

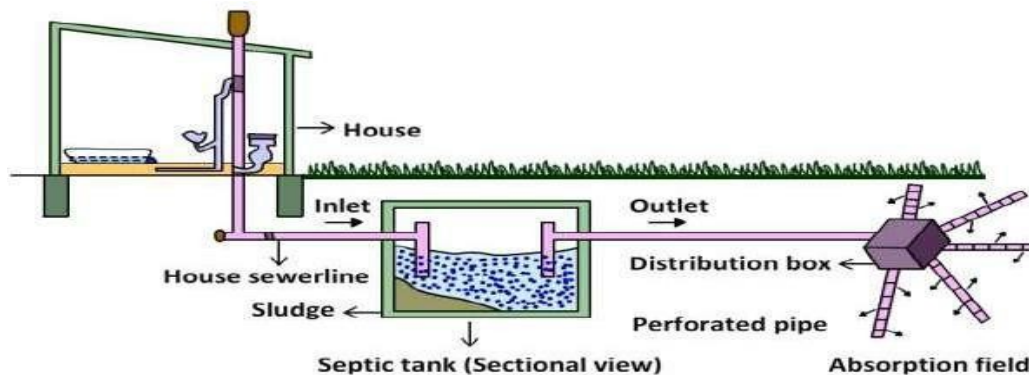

### **Tertiary Treatment**

- This treatment is sometimes called as the final or advanced treatment and consists of removing the organic matter left after secondary treatment, removal of nutrients from sewage, and particularly to kill the pathogenic bacteria.
- Disinfection is normally carried out by chlorination for safe disposal of treated sewage in water body which is likely to be used at downstream for water supplies.
- However, for other reuses tertiary treatment is required for further removal of organic matter, suspended solids, nutrients and total dissolved solids as per the needs.

Detention time :-

- Detention time is the length of time water is retained in a vessel or basin or the period from the time the water enters a settling basin until it flows out the other end.
- When calculating unit process detention times, we are calculating the length of time it takes the water to flow through that unit process.

### **Gulley Traps**

- Gulley Traps are Used to prevent foul odours emitted from the sewer from reaching buildings and apartments.
- Gully traps are provided on wastewater pipes before they are connected to the building sewer through a chamber.
- The main purpose of a gulley trap is to prevent foul air from entering the building through wastewater pipes.
- It should maintain a 65mm water seal at all times.
- It is essential the gulley trap is embedded in cement

### **Self-purification process of a river or stream**

Natural Purification in streams and Rivers :-

- Natural forms of pollutants always present in surface water.
- In the early civilization, many of the impurities were washed from the air, eroded from land surface, or leached from the soil ultimately reached to surface water.
- The self purification processes were able to remove or render these materials harmless.
- As civilized evolved, human activity increased the amount and changed the

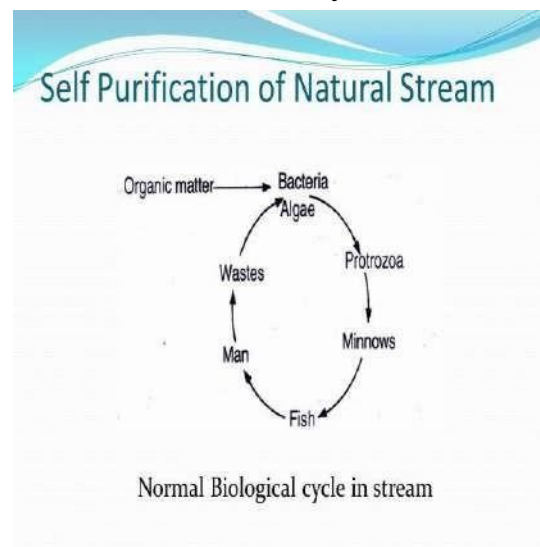

nature of pollutants entering water bodies.

- As settlements grew into villages, villages into towns, cities and megacities, the quantity of waste products increased until the self purification capacity of water bodies was exceeded.
- Smaller streams were affected first, with larger streams and lakes ultimately becoming polluted.
- When decomposable organic waste is discharge into a water body, a series of physical, chemical and biological reactions are initiated.
- The stream relieved of its pollution burden.
- This process is known as Self purification or natural purification process.
- This process continuously changing water quality characteristics through out the stream.
- The speed and completeness with which these processes occur depend on many variable like volume, flow rate, turbulence of flow, variation in sunlight and temperature.
- Flowing water bodies like streams, canals and rivers can recover rapidly from degradable, Oxygen demanding wastes and excess heat through a combination of dilution and bacterial decay.
- This natural recovery process works as long as pollutants do not overload the stream and drought, or water diversion for agriculture or industry do not reduce their flows.
- However, these natural dilution and biodegradation processes do not eliminate slowly degradable and non degradable pollutants.

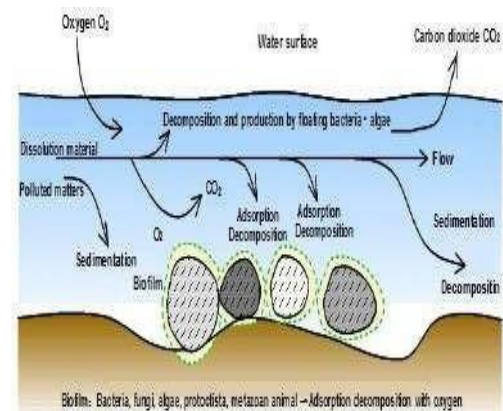

- In a flowing stream, the breakdown of degradable wastes by bacteria depletes dissolved oxygen.
- This reduces or eliminates populations of organisms with high oxygen requirements until the stream is cleansed of wastes.
-

## Chapter 11

### SANITARY PLUMBING FOR BUILDING

#### Requirements of building drainage

- Drainage systems is a piping system which disposes household effluents.
- It consists of two features which work together :

1. the outdoor

2. domestic pipelines.

#### Main requirements for outdoor systems

- The outdoor drainage system is distribution pipelines which are extend from the building to the pump station where the waste water is stored.
- When designing the outdoor drainage system the following requirements should be observed: -
  - i. The minimum diameter of pipes and fittings for outdoor pipelines is 100 mm and in this case deviation is not less than 0.01%, and deviation for pipeline DN150 is 0.008%;
  - ii. The angle between the discharge pipe and affiliable pipe must be at least  $90^\circ$
  - iii. The minimum installation depth of the pipeline must be 0.7 m in areas where vehicles may ride, and in

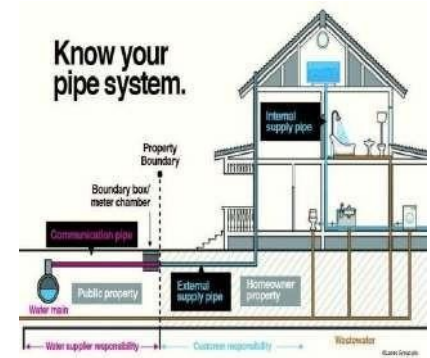

other areas it must be 0.5 m.

iv. However, the outdoor drainage system should be installed below the depth of soil freezing.

v. If installation of the pipeline below the depth of soil freezing is not possible, it should be insulated, that there was no obstruction of pipes.

- Also when selecting pipes for outdoor drainage system and their installation you should take into account the following: -

- For regular cleaning and maintenance of pipelines, inspection chambers must be installed .

- If local factors do not allow to design gravity pipe system, force main sewerage should be installed, and for it the special pipes must be used i.e they are designed for the work under pressure.

- Usually they are made of cast iron, asbestos cement or plastic.

- Connections of the pipeline should not have displacement which disturb integrity of the system during seasonal increase level of ground waters.

- Pipes, which can withstand the load of vehicles and pedestrians, should be installed in areas that intersect with highways, as well as in areas with increased load.

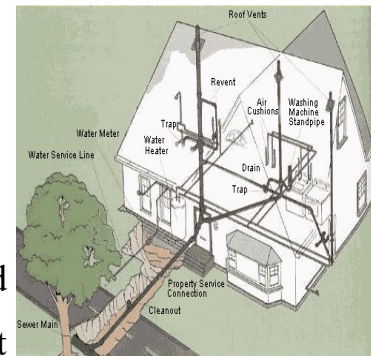

### **Main requirements for domestic drainage systems**

- Domestic drainage system consists of the following elements:

i.Plumbing fixture, work of which produces effluents  
(exception – heated towel rail);

ii. Pipes which dispose effluents from plumbing fixture  
to drainage system;

iii. Main sewer.



- As for outdoor drainage system, specific requirements are developed, and they must be followed when installation of drainage system.

- All pipeline equipment for domestic drainage system should have high capacity - this will avoid frequent and time consuming cleaning of the pipeline.



- Also it should withstand test pressure which exceeds the working pressure by 1.5 times, but not less than 0.68 MPa or about 7 bar, and the permanent pressure corresponding to the operating pressure, but not less than about 0.45 MPa or 4.5 bar.

- Also the pipes should be:

Durable;

Resistant to low and high temperatures;

Smooth inside i.e. smooth inner surface allows to avoid frequent clogging;

Mechanically and chemically wear resistant;

strong

Compatible with outdoor drainage system.



Additionally, you should choose such pipes that are easy to install.



## Operation rules of drainage systems

All drainage systems should be operated following the basic rules:

- Cleaning and maintenance of the pipeline should be carried out regularly;
- All of the pipeline elements must be sealed completely for reducing likelihood of leakage;
- Diameters of the pipeline equipments must be such that the wastewater will be disposed without interruption;
- You should avoid the overload not only the whole system but also its separate elements;
- You should monitor the concentration of toxic substances contained in the effluents, because high concentration of toxic substances can damage the treatment facilities.

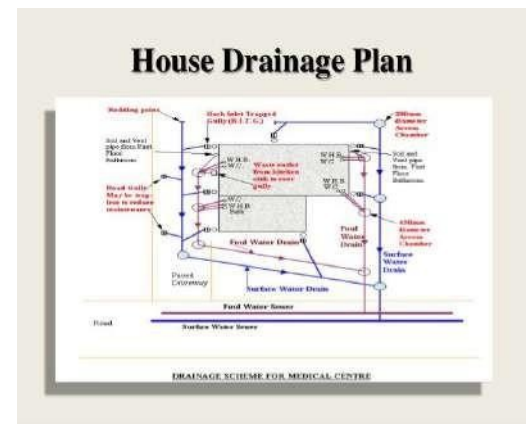

- If we will observe this rules, the pipeline will serve a long time with minimum of failures.

### **Common sanitary fittings and fixtures**

- We must have seen plumbing and sanitary fittings and fixtures installed in the kitchen, bathroom or toilets of our home, school or other buildings.
- Many people confuse the words plumbing fittings and plumbing fixtures.
- A plumbing fixture is a part that is connected to a plumbing system and carries water through a building.
- The most common plumbing fixtures are bathtubs, sinks, showers, tubs, toilets and faucets or taps.
- While a fixture can be fixed into walls or the floor, a fitting is an item that can be hung by a hook, screw or nail.

### **Plumbing fittings**

- Various types of pipe fitting are available in plumbing systems for different purposes and functions.
- A pipe fitting is used in the plumbing system to join multiple pipes of same size or different sizes, to regulate the flow or to measure the flow.
- They are mad up of different materials like copper, iron, brass, PVC, etc.
- There are many different kinds of fittings, made from a variety of materials.
- For a building, the plumbing system should be designed in such a way that water is distributed uniformly throughout the day.

- It should be ensured that a combination of fittings and fixtures is selected in such a way that uniform supply of water and discharge of water is maintained.

## Sanitary fixtures

### 1. Water Closets (W.C):

- It is provided to receive human excreta directly from the user.
- It is connected through a suitable trap to the soil pipe and finally to a municipal sewer or septic tank.



- The excreta is flushed with the help of water from the cistern tank.
- There are two types of water closets:

1. Indian type or squat toilet
2. European type or flush toilets

#### 1. Indian type or squat toilet

- The most common toilet is used in our nation is the Squat toilets, in which water carries the waste into sewers.

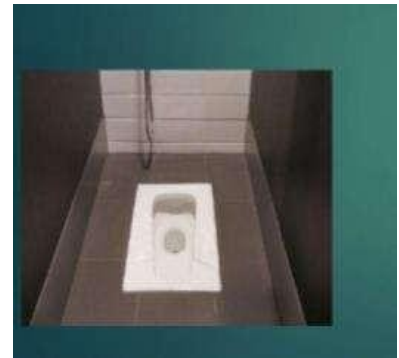

#### 2. European type or Flush toilets:

- The most common design in western countries is the sitting toilet.
- Flush Toilet are still used by the majority of the world's population.



## Components of water closet

The main components of water closet are :

1. bowl
2. tank
3. pipelines



## URINAL

- They are designed to accept and dispose of liquid human wastes only.
- The types of urinal are ceramic slab , stall type and bowl type.
- The slab type is cheaper than the stall type , but it does not provide the same degree of privacy.

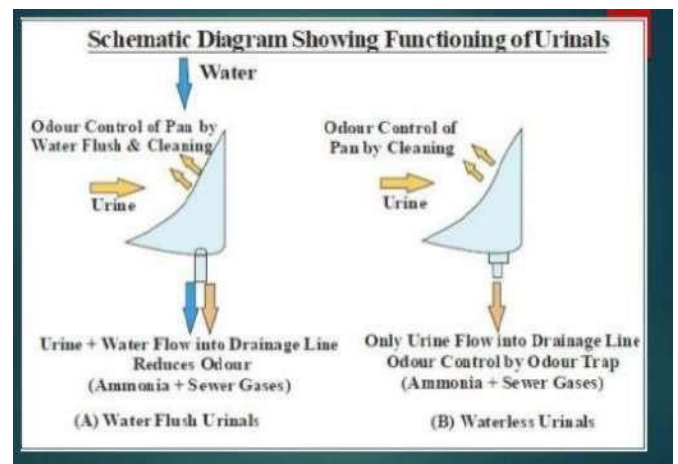

- The installation of ceramic bowl-type urinal, which have less fouling area than the slab and stall urinals.

## Flushing cisterns

- It is used for storage and discharge of water for flushing of w.C. Or urinals.
  - It is made of cast iron vitreous china or pressed steel plates or plastic.
- The capacity varies from 10 to 15 liters.
  - When the cistern is fixed at a height of 1.8 to 2 m from floor it is termed as high level cistern made of cast iron.

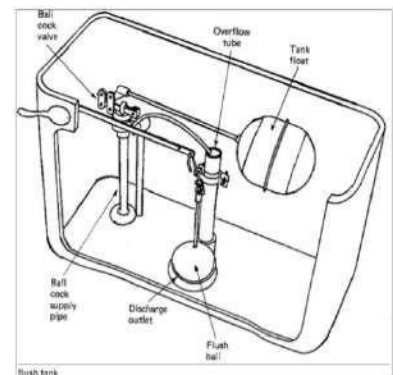

## Types of flushing cisterns :

There are 4 types of flushing cisterns are available as follows :

1. Valve less siphonic type or bell type.
2. Valve fitted type or piston type.
3. Automatic flushing type.
4. Flush valve

### 1. Valve less siphonic type or bell type

- The bell type flushing cistern is rather noisy but may be used in factories and schools.
  - The cistern is operated by chain being pulled over which lifts the bell.
  - When the chain is released the bell falls thus displacing water under the bell down the sand pipe.
  - Siphonic action is then created which empties the cistern.

#### Bell Type Flushing Cisterns

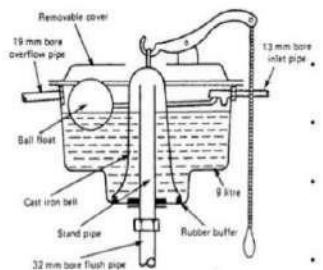

### 2. Valve fitted type or piston type

- When the lever is depressed sharply, the piston is lifted which displaces water over the siphon.
- Water discharging down the flush pipe takes some air with it and creates a partial vacuum in the siphon.
- The greater air pressure acting upon the water in the cistern forces water through the siphon until air is admitted under the piston which breaks the siphonic action.

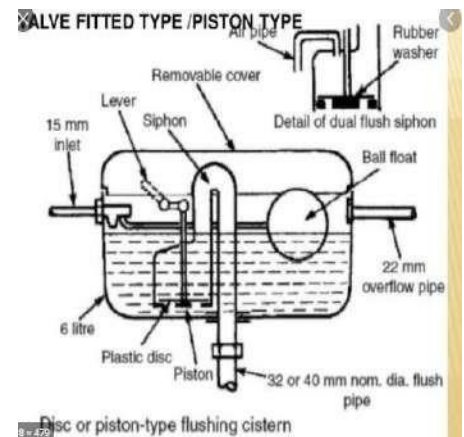

### 3. Automatic flushing type

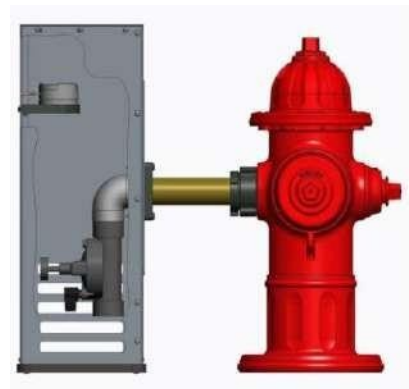

Automatic cistern are designed to discharge its contents of water at regular intervals into a urinal.

The rate at which the water will flush depends upon the rate at which the water is fed into the cistern and for a single installation this should not exceed ten liters per hour.

